

# OPERATOR'S MANUAL

MILLCREEK MODELS:  
3100/3200 TURF TIGER® SPREADERS

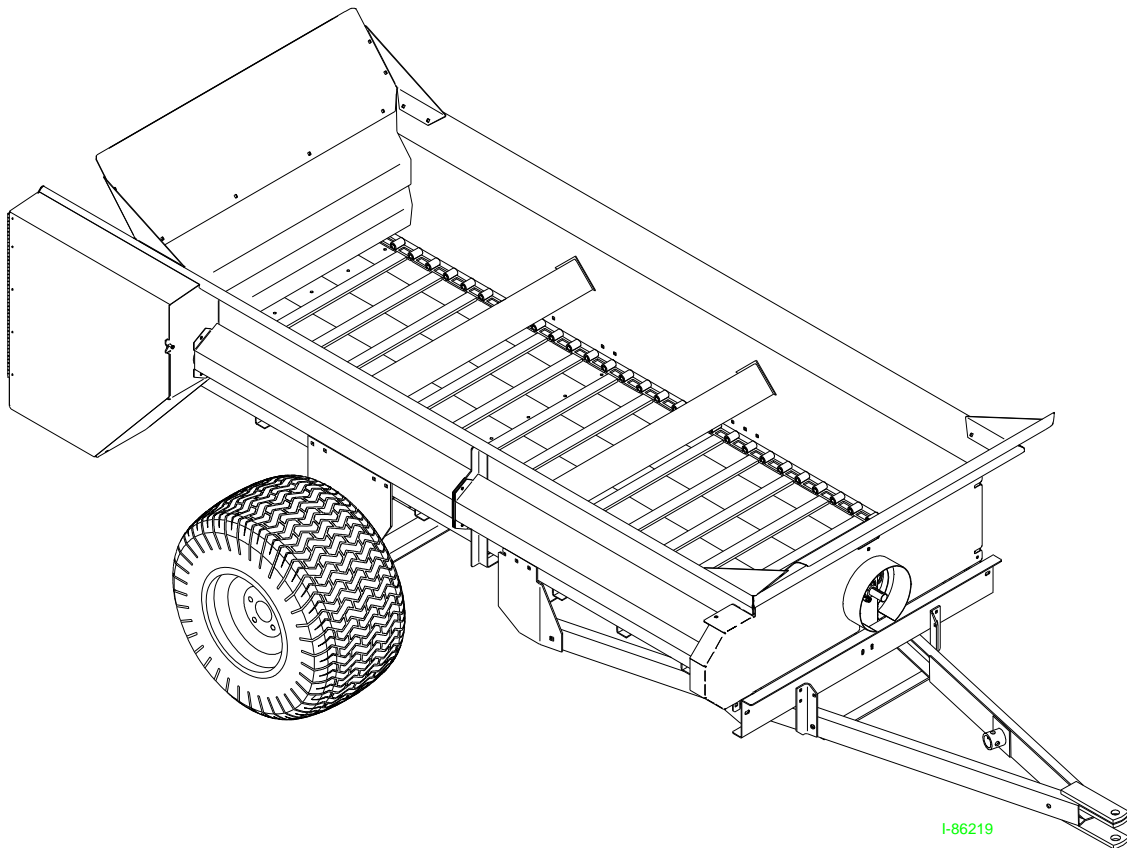

PUBLICATION DATE: 1/13/09, Rev. 3

MILLCREEK PART # 43827

Millcreek Manufacturing Company  
525 Reservoir Road  
Honey Brook, PA 19344  
Phone: 1-800-311-1323  
[www.milkcreekspreaders.com](http://www.milkcreekspreaders.com)



**WARNING: DO NOT assemble, operate, or maintain this equipment without first reading and understanding the information provided in this manual and the ADMA Safety Manual for Agricultural Implement Drivelines. Failure to follow all safety precautions as stated in these manuals may result in serious personal injury or death.**

**VISIT OUR ONLINE PARTS STORE!**

**<https://parts.millcreekmfg.com>**

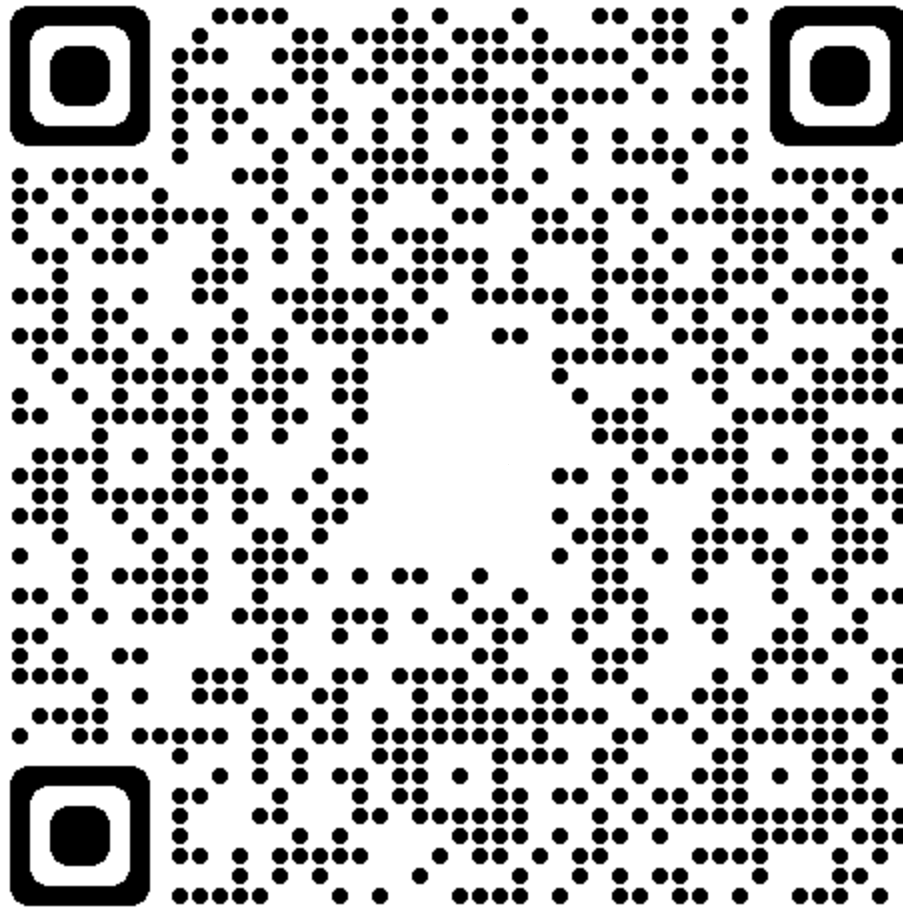

**MILLCREEK MANUFACTURING WARRANTY**  
**Manure Spreaders**

Millcreek Manufacturing (hereafter called the Company) aims to manufacture quality equipment that is free from defects in materials and workmanship. The Company offers a **THREE YEAR FULL COVERAGE WARRANTY** on all parts included on the spreader, with *no exceptions*. If any part breaks or malfunctions within this timeframe, simply give us a call at 1-800-311-1323 and we will replace it for you, free of charge.

The Company offers a **TEN YEAR WARRANTY** on all spray-on polyurethane lining.

The Company offers a **LIFETIME WARRANTY** against cracking or rotting on all poly floor boards.

The Company offers a **LIFETIME WARRANTY** against any rust damage on all stainless steel spreader bodies.

The Company extends this warranty solely to the original purchaser of the machine, meaning the person for whom the equipment is originally supplied. The warranty is valid only within the Continental United States.

The Company cannot guarantee that circumstances beyond its control may affect its ability to obtain or manufacture replacement parts. In these rare events, the Company will make every effort to obtain similar parts, or offer an alternate solution.

***This warranty is made in lieu of all other warranties, expressed or implied.***



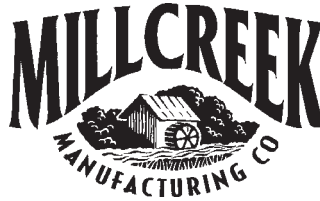

## \*\*\* ASSEMBLY INSTRUCTIONS \*\*\*

### Model 3100/3200 TURF TIGER® Spreaders

#### Removing the Shipping Crate from the Spreader

##### Tools Needed:

- Claw Hammer
- 1/2", 9/16", and 3/4" Wrenches or Socket Sets

1. Use a claw hammer to loosen the top of the shipping crate. Start at one end, and loosen across the entire end. Continue prying up the top of the crate through the middle and down to the opposite end.
2. Carefully remove the top of the shipping crate, including the cross brace that extends across the middle.
3. Use the claw hammer to loosen and pull off the side posts of the shipping crate.
4. Note that the following items are packed inside the spreader box:
  - Jack
  - Loading Flares
  - Assembly hardware
  - Owner/operator documentation
  - Hitch brackets
  - Hitch
  - PTO shaft assemblyIf desired, you may unload these items at this time.
5. The spreader box is blocked up in the shipping crate (front and back), and the wheels/tires are underneath the spreader box on the floor of the crate. Locate and remove the two (2) stabilizing bolts and galvanized brackets from the *front bottom* of the spreader. (You will find one bolt and bracket on each side of the spreader at the front.)
6. Use a fork lift to carefully lift the spreader box up and out of the shipping crate.  
 **CAUTION:** Approximate weight of the spreader is 1,000 pounds (Model 3100) or 1,200 pounds (Model 3200). To prevent personal injury, Millcreek recommends that you secure the spreader box to the forklift with a strap/chain when lifting it out/off of the shipping crate.
7. Prepare a secure car jack stand or equivalent to support the spreader box during assembly. Lower the spreader from the lifting device and ensure that it is securely supported/blocked up for safe assembly. Recommended height for assembly of the wheels, hitch, etc. is 18 to 24".
8. Remove the wheels/tires from the shipping crate and set aside for assembly.

## Assembling the Hitch



**WARNING:** To prevent personal injury while working on the spreader for all assembly procedures, make sure the spreader box is securely blocked up so that it cannot fall.

**ATTENTION:** For safe and proper operation of the spreader, adhere to the following specifications for tightening the hitch hardware; failure to tighten all hitch hardware securely may result in equipment damage.

<u>Hardware</u>	<u>Torque Specification</u>
1/2"	60 ft. lbs.
3/8"	25 ft. lbs.
5/16"	15 ft. lbs.

1. Refer to Figure 1.
2. Attach the two smaller hitch brackets to the lower front flange of the spreader box as shown. Use the 5/16" x 3/4" carriage bolts and flange nuts provided.
3. Attach the two larger hitch brackets to the spreader box (one on each side). Align the pre-drilled holes on the top of each bracket with the pre-drilled holes on the side sheet of the box. Use the 3/8" x 3/4" carriage bolts and nuts provided.

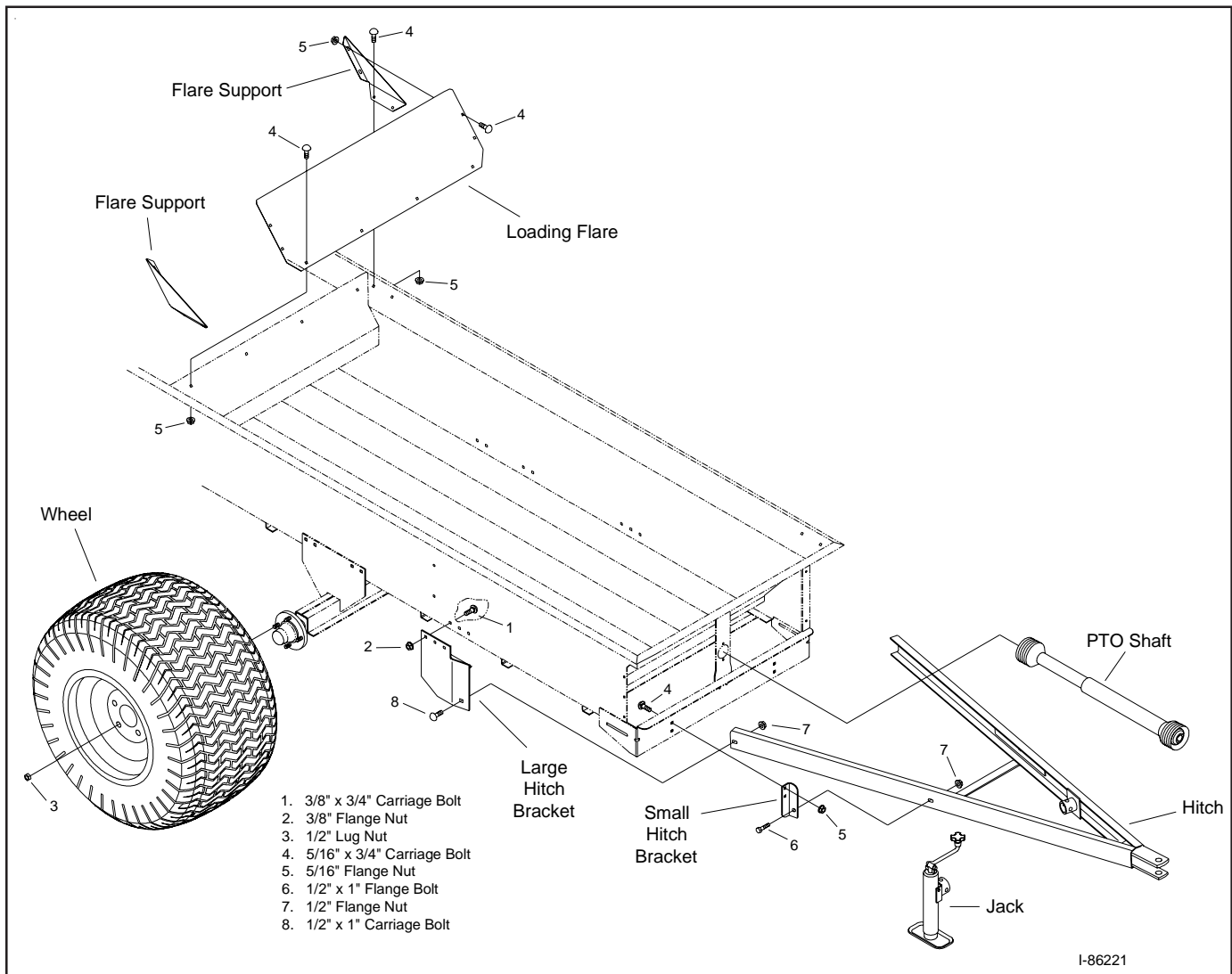

**Figure 1 - Detailed Overview of Model 3100/3200 Spreader Assembly**

## Assembling the Hitch (continued)

4. Position the legs of the hitch into the mounting brackets as shown, being sure to carefully align the pre-drilled holes on the hitch legs with the holes in the mounting brackets.
5. Fasten the legs of the hitch to the larger mounting brackets (one on each side) towards the rear of each leg of the hitch using the hardware provided (1/2 x 1" carriage bolts, 1/2" flange nuts).
6. Fasten the hitch to the smaller mounting brackets at the front of the spreader box as shown. Use the 1/2 x 1" flange bolts and nuts provided.
7. **Ensure that ALL hitch mounting hardware is tightened securely as specified.**

## Installing the Wheels

1. To install each wheel, align the hole in the wheel with the stud on the hub.
2. Install the five (5) wheel lug nuts on each wheel.
3. After each wheel has been installed, torque the wheels to 75 to 80 ft. lbs.
4. Check the tires and inflate them to the recommended pressure, 18 psi.

## Installing the Jack

1. Refer to Figure 1 for positioning of the jack.
2. Slide the jack assembly into the mounting receptacle on the front of the hitch.
3. Secure the jack in place with the jack pin and chain provided.

## Installing the PTO Shaft and Safety Chain

**NOTE:** Important safety instructions from the manufacturer are provided with the PTO; please keep these instructions with the Spreader Operator's Manual.

1. Refer to Figures 1 and 2.
2. Plug the PTO shaft assembly into the receptacle on the front of the spreader, being sure to align the key in the shaft with the key in the yoke.  
**ATTENTION:** The PTO key is held in place with a rubber cap on the stub shaft on the front of the spreader box (*remove the cap before installing the PTO shaft assembly onto the stub.*)
3. Check for proper alignment by ensuring that the inside of the PTO yoke is flush with the end of the stub shaft as shown in Figure 2.
4. Tighten the set screws in the PTO shaft to secure it in position. Access the screws from the bottom of the shaft as shown.
5. **IMPORTANT: Attach the PTO safety chain to either small hitch bracket on the front of the spreader box; clip the chain in the top unused hole on the bracket.**

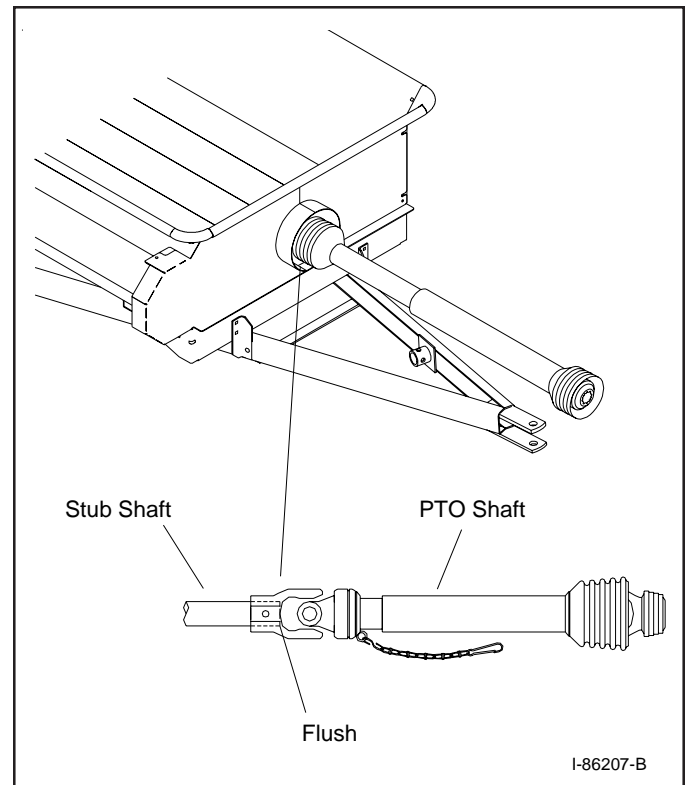

**Figure 2 - Installing the PTO Shaft**

## Assembling the Loading Flares

1. Refer to Figure 1 for positioning of the loading flares; note that parts for two (2) loading flare assemblies are provided (one for the front and one for the rear).  
**NOTE:** You may also refer to the **TURF TIGER Metering Endgate Assembly Parts Detail** in **Appendix A** at the back of the **Operator's Manual** supplied with the spreader.
  2. Assemble each loading flare and two (2) flare support pieces using the 5/16 x 3/4 carriage bolts and flange nuts provided.
  3. Loosely fasten the rear loading flare assembly to the rear of the spreader box as shown in Figure 1 using the 5/16 x 3/4 carriage bolts provided. When you are assured that the loading flare is positioned properly, tighten the bolts firmly.
  4. Repeat step #3 for the front loading flare assembly.
- 

**IMPORTANT NOTE:** If the spreader was ordered with any of the following options, separate parts/assembly drawings are provided at the back of the **Operator's Manual, Appendix B**. Please contact Millcreek for additional instructions as needed.

- Safety Chain (for transportation on public roadways)
- Slow Moving Vehicle Sign





---

# TABLE OF CONTENTS

<b>SECTION 1: INTRODUCTION .....</b>	<b>1-1</b>
Guide to this Manual .....	1-1
For Your Safety... ..	1-1
Safety Labels .....	1-2
Inspection and Warranty Registration .....	1-5
Warranty Registration .....	1-5
<b>SECTION 2: ATTACHING THE SPREADER TO THE TRACTOR .....</b>	<b>2-1</b>
Connecting the Spreader Hitch to the Tractor Drawbar .....	2-1
Attaching the Spreader to the Tractor PTO .....	2-2
<b>SECTION 3: OPERATION &amp; ADJUSTMENT .....</b>	<b>3-1</b>
Understanding TURF TIGER® Spreader Operation .....	3-1
TURF TIGER Spreader Operating Components .....	3-1
Guidelines for Loading the TURF TIGER Spreader .....	3-1
Operating the TURF TIGER Spreader .....	3-1
Adjusting the TURF TIGER Spreader .....	3-2
Adjusting Tractor Ground Speed .....	3-2
Adjusting the Metering Endgate .....	3-2
Recommended Settings for TURF TIGER Spreader Operation .....	3-3
Material Weights (Range Per Cubic Yard) .....	3-3
Material Volume Estimation .....	3-3
Initial Adjustments (Sample Settings) .....	3-4
<b>SECTION 4: MAINTENANCE &amp; ADJUSTMENT .....</b>	<b>4-1</b>
Guidelines for Regular Maintenance .....	4-1
General Maintenance .....	4-1
Wheel/Tire Maintenance .....	4-1
Wheel Bearing Maintenance .....	4-2
Procedures for Spreader Adjustment .....	4-2
Checking and Adjusting the Floor Apron Chain .....	4-2
Checking and Adjusting the Apron Drive Chains .....	4-3

---

---

# TABLE OF CONTENTS

<b>APPENDIX A: PARTS REFERENCE .....</b>	<b>A-1</b>
General TURFTIGER® Spreader Specifications .....	A-1
Component Parts Ordering Information .....	A-2
TURFTIGER Spreader Box and Hitch Assembly .....	A-2
TURFTIGER Spreader Wheel/Hub Assembly .....	A-4
TURFTIGER Rear Drive Assembly .....	A-6
TURFTIGER Front Drive Assembly .....	A-8
TURFTIGER Apron Chain and Sprocket Assembly .....	A-10
TURFTIGER Safety Shields and Guards .....	A-12
TURFTIGER PTO Shaft Assembly .....	A-14
TURFTIGER Metering Endgate Assembly .....	A-16
<b>APPENDIX B: OPTIONAL PARTS REFERENCE .....</b>	<b>B-1</b>
Safety Chain Assembly .....	B-1
Pathmaker Assembly .....	B-2
Pathmaker Mounting Instructions .....	B-2
Slow Moving Vehicle Sign .....	B-4
<b>APPENDIX C: ENGINE DRIVE .....</b>	<b>C-1</b>

---

## SECTION 1: INTRODUCTION

### Guide to this Manual

This manual contains all the information necessary to safely operate and maintain the Millcreek Model 3100 and 3200 TURF TIGER® Spreaders. Consult the Table of Contents for a detailed list of topics covered. You'll find this manual's step-by-step procedures easy to follow and understand. Should questions arise, please contact your Millcreek dealer before starting any of the procedures in this manual.

**NOTE: Procedures provided in this manual apply to *both* spreader models (Model 3100 and Model 3200) unless specifically noted otherwise.**

Regarding the information presented in this manual:

- All safety, operating, and servicing information reflects current production models at the time of publication of this manual.
- References made to left, right, front, and rear are those directions viewed when facing the unit from the rear.

*Please read all sections in the manual carefully--including the important safety information found in this section--before beginning any assembly/operation procedures; doing so allows you to use your Millcreek Spreader safely with optimal performance.*

---

### For Your Safety...

For your safety, Millcreek documentation contains the following types of safety statements (listed here in order of increasing intensity):

- **NOTE:** A clarification of previous information or additional pertinent information.
- **ATTENTION:** A safety statement indicating that potential equipment damage may occur if instructions are not followed.



**CAUTION:** A safety statement that reminds of safety practices or directs attention to unsafe practices which could result in personal injury if proper precautions are not taken.



**WARNING:** A *strong* safety statement indicating that a hazard exists which can result in injury or death if proper precautions are not taken.



**DANGER!** *The utmost levels of safety must be observed;* an extreme hazard exists which would result in high probability of death or irreparable serious personal injury if proper precautions are not taken.

*The best operator is a careful operator.* By using common sense, observing general safety rules, and adhering to the precautions specific to the spreader, you, the operator, can promote safe equipment operation.

## For Your Safety... (continued)

In addition to observing the specific precautions listed throughout the manual, **the following general precautions apply and *must be heeded* for proper, safe operation.**



**WARNING:** Keep hands and feet from under the spreader at all times. Ensure that you are safely distanced from any other persons before operating the spreader.



**WARNING:** DO NOT attempt to operate the spreader in areas with steep inclines, ditches, large rocks, stumps, or holes which may endanger the operator by upsetting the tractor or cause damage to the spreader.



**WARNING:** To prevent serious personal injury and to promote safe spreader operation, keep all shields in place during operation. Ensure that all mounting hardware is properly tightened.



**WARNING:** Never clean, adjust, or repair the spreader while the tractor is running.



**WARNING:** Never get off the tractor while it is in motion, while the spreader is in operation, and/or while the PTO is engaged.



**WARNING:** Never wear loose clothing when operating the spreader as it may become caught in the moving parts of the machine.



**WARNING:** Never allow children or anyone else to ride on the spreader.

**ATTENTION:** For proper and safe operation of the spreader, periodically inspect all parts for excessive wear. Replace worn components with factory-authorized parts.

### **Safety Labels**

Following are the locations and descriptions of all labels on your TURF TIGER spreader. Figure 1A shows the location of ALL labels on your spreader. Please note that some labels denote model number, model description, etc. while others contain important safety messages.

Each **Safety Label** contains an important safety message starting with a key word as discussed earlier in this section (e.g. ATTENTION, CAUTION, WARNING, DANGER). For your safety and the safe operation of your spreader, review all labels and heed all safety messages as printed on the labels.

Be sure to keep the safety labels clean and readable. If the labels ever become damaged or illegible, contact your Millcreek dealer for replacements.

**Safety Labels (continued)**

**TURF TIGER Spreader Safety Labels**

<b><u>Label Part #</u></b>	<b><u>Description</u></b>
42792	DANGER - NO riders
42710	WARNING - Flying Debris
42756	WARNING - Entanglement, Do NOT operate without shields
42772	WARNING - Spreader combination safety label - moving parts, read manual
42778	Millcreek Logo Label
42781	Model 3100 Serial Number Label
42782	Model 3200 Serial Number Label
42788	Model 3100 Label
42789	Model 3200 Label
42790	TURFTIGER Spreader Logo Label
42810	Model 3100 Load Limit Label
42811	Model 3200 Load Limit Label

***For your safety, be sure to locate all safety labels and review their content before proceeding with operating the spreader!***

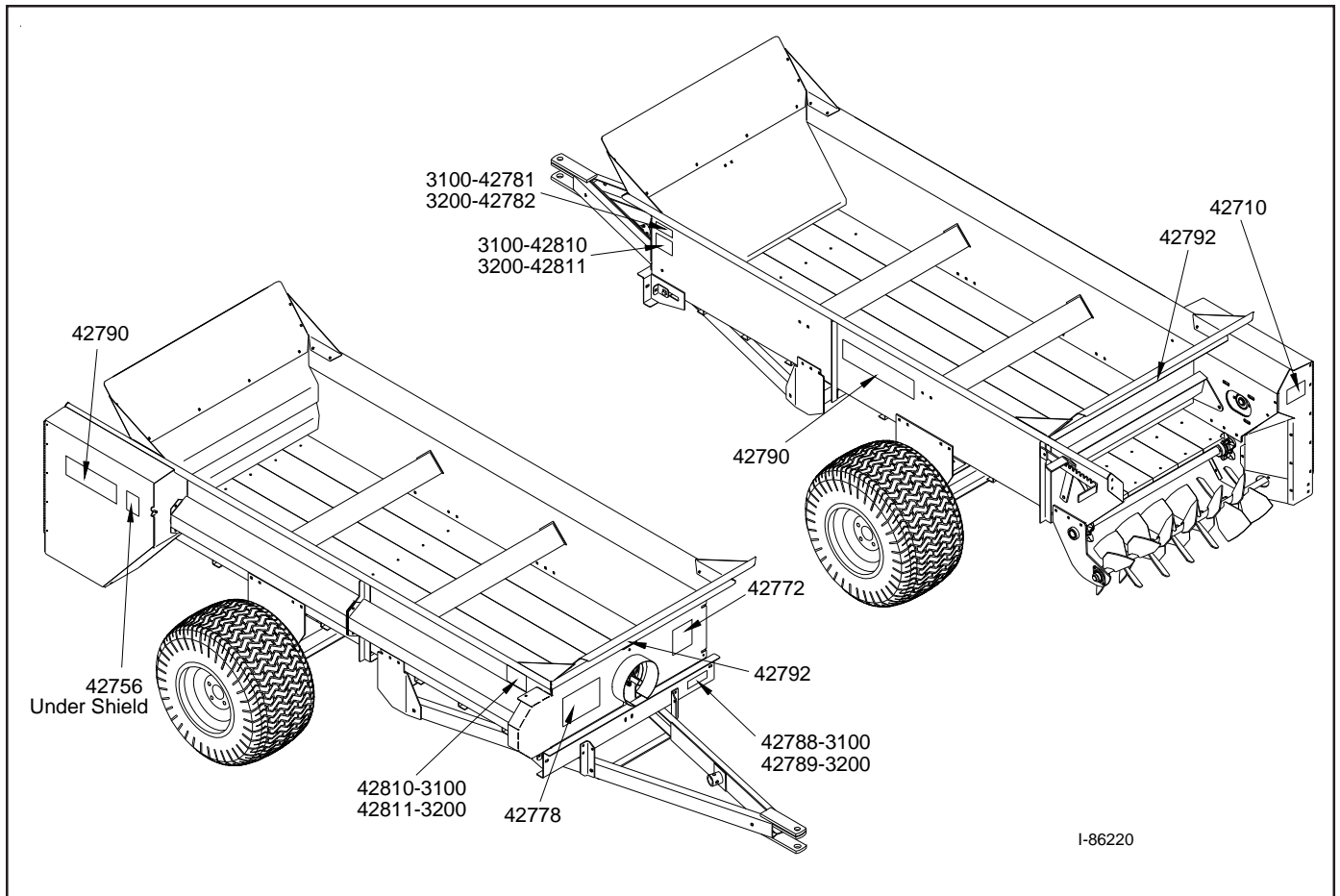
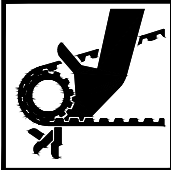

**Figure 1A - Safety Label Locations**

**Safety Labels (continued)**

**⚠ DANGER NO RIDERS** 42792

**⚠ WARNING**  
**Entanglement Hazards**



**Moving parts can crush or cut.**

**STAY CLEAR** of machine while engine is running and/or machine is operating. Keep hands, feet, clothing, and hair away from operating parts.



**Never** adjust, lubricate, or clean machine while engine is running and/or machine is operating.

**Never** operate machine without safety shields in place.



**Read and understand** operator's manual and safety labels before operating or servicing the machine.

**Failure to follow these warnings may result in serious injury or death.**

42772

**⚠ WARNING**



**Entanglement Hazard.**

**DO NOT OPERATE** without safety shield in place. Moving parts can crush and cut.

42756

**ATTENTION**

**DO NOT EXCEED  
 3000 lbs PAYLOAD  
 10 mph max loaded**

42810

Model 3100

**ATTENTION**

**DO NOT EXCEED  
 3750 lbs PAYLOAD  
 10 mph max loaded**

42811

Model 3200

**⚠ WARNING**



**Entanglement / Flying Debris Hazards.**

**DO NOT STAND** in back of machine while engine is running and/or machine is operating. Rotating beaters and/or flying debris can cause serious personal injury or death.



Approach the rear of the machine **ONLY** when all power sources are shut OFF and all moving parts have stopped.

42710

## Inspection and Warranty Registration

Most spreader models are shipped from your Millcreek Dealer completely assembled and ready for operation. Inspect your new spreader thoroughly upon receipt to ensure that it has been shipped to you in a satisfactory manner. Immediately notify the freight company and your Millcreek dealer in case of shipping damage, shortage(s), and/or errors.

**The TURF TIGER Spreader is supplied with the following operating features/components (standard):**

- Adjustable Metering Gate
- Loading Flares
- PTO Shaft
- Jack
- 26.5 x 14 x 12 (4-ply) Turf Tires

**NOTE:** If the spreader has not been pre-assembled, please refer to the *Supplemental Assembly Instructions*. Please contact your local Millcreek Dealer for assistance as needed.

Your spreader shipment may also include the following options:

- Safety Chain
- Slow Moving Vehicle Sign
- Pathmaker
- Engine Drive\*

Instructions for assembling these items are provided in **Appendix B and C** at the back of this manual. Please contact your local Millcreek Dealer for assistance as needed.

**\*NOTE:** If you ordered a **Model 3100 Engine Drive**, please also refer to the **Supplemental Instructions, Millcreek Part #43837**, for additional important information about the operation of that unit.

Following inspection of your new spreader, locate the Millcreek Warranty Card in the literature packet shipped with your spreader. For proper warranty registration, Millcreek requires that you fill out the warranty registration card and return it *within 30 days* to:

MILLCREEK WARRANTY REGISTRATION  
Millcreek Manufacturing Company  
34 Zimmerman Road  
Leola, PA 17540

**For your safety, be sure to locate all safety decals and review their content before proceeding with operating the spreader.**





## SECTION 2: ATTACHING THE SPREADER TO THE TRACTOR

### Connecting the Spreader to the Tractor

The spreader hitch is designed to work with a standardized tractor hitch. To connect the spreader hitch to the tractor hitch, refer to Figure 2A and adhere to the following guidelines:

- Adjust the drawbar so that it is 13 to 20 inches above the ground as shown in Figure 2A.
- **For PTO units only:** Extend or shorten the tractor hitch to obtain the horizontal distance from the end of the tractor power take-off (PTO) shaft to the center of the hitch pin hole (Figure 2A).
- Adjust the height of the spreader hitch with the jack so the tractor drawbar matches the height of the spreader hitch.
- Back the tractor into the hitch until the holes line up.
- Fasten the spreader hitch to the drawbar with a hitch pin that fits securely (i.e. so that it will not come out during spreader operation) and lock in place with the clip as shown.
- Remove the weight from the jack by lowering the spreader hitch on the drawbar.
- Swing the jack to its horizontal position and lock it in position to provide maximum ground clearance.
- **ATTENTION: Be sure the 3-point hitch brackets on the tractor are adjusted to clear the spreader hitch while turning,** or equipment damage may occur.



**WARNING:** Damage to the spreader or other vehicle, as well as injury to the operator, may occur if a properly-sized hitch pin is not installed as recommended. Note that the installation of the safety clip, as noted in Figure 2A, is also required for safe spreader operation.

**ATTENTION:** An improperly located hitch point may cause damage to the universal joints of the PTO. The recommended length of the PTO shaft should range from 36 to 51 inches center to center of the "U" joints.

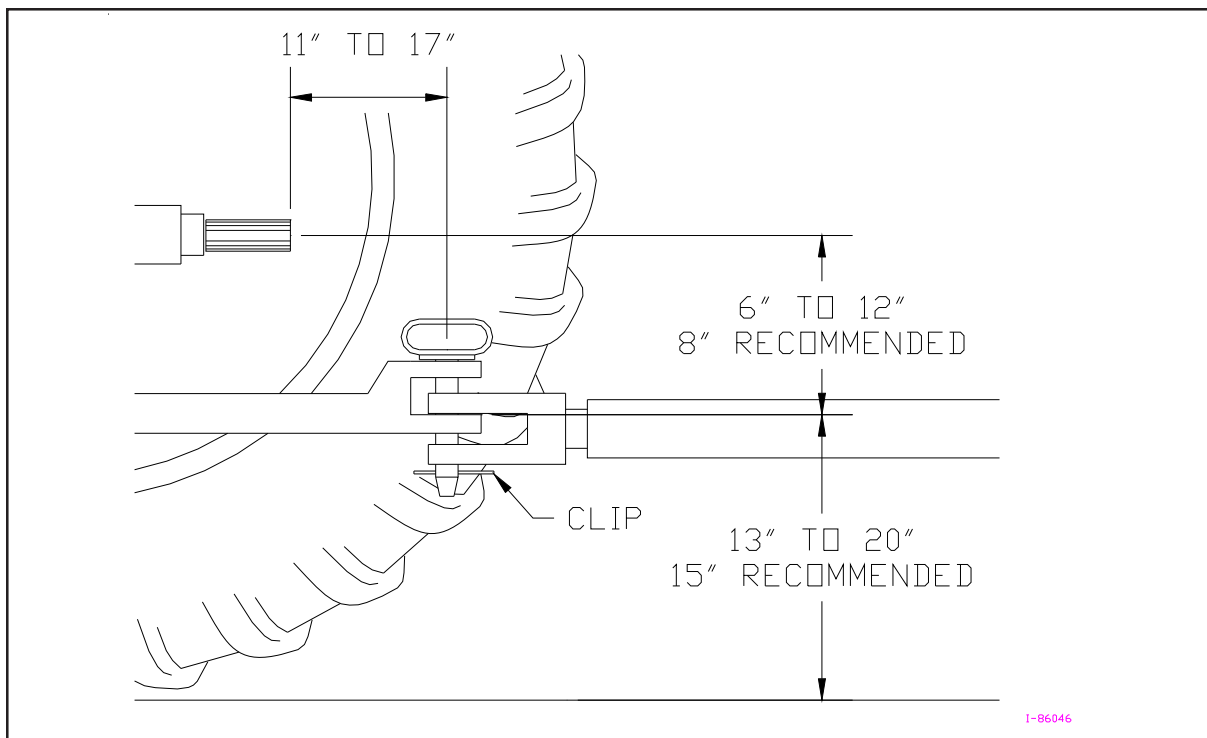

**Figure 2A - Specifications for Connecting the Spreader/Tractor Hitch**

## Attaching the Spreader PTO to the Tractor PTO

**NOTE:** *If you have a Model 3100 Engine Drive, these instructions do NOT apply.*

1. Release the ball bungee that secures the PTO to the PTO Holder.
2. Fold down the PTO Holder so it lays against the hitch.



**CAUTION:** Failure to fold down the PTO Holder before the PTO is connected to the tractor will result in equipment damage.

3. Align the PTO splines on the spreader with the PTO splines on the tractor.
4. Pull back the slide collar on the PTO yoke, and slide the spreader PTO assembly onto the tractor PTO shaft. ***Be sure the slide collar snaps forward to indicate that the spreader PTO assembly is properly secured to the tractor PTO shaft.***



**WARNING:** Make sure that the PTO safety chain is attached to one of the hitch brackets on the front of the spreader (fasten to upper unused hole in bracket). ***Failure to secure the PTO safety chain will allow the safety shield to rotate.*** Operating the spreader without the safety shield in proper position may result in serious personal injury or death.

## SECTION 3: OPERATION & ADJUSTMENT

### Understanding TURF TIGER® Spreader Operation

Proper and safe operation of the Millcreek 3100/3200 TURF TIGER spreaders requires: (1) being familiar with the spreader operating components and (2) heeding all safety precautions as stated in this manual.

**NOTE:** *If you have a Model 3100 Engine Drive, be sure to also review the important information on operation (specific to that unit) provided in the separate addendum, Millcreek Part #43837. Please disregard any discussion in the following pages with regard to PTO shafts or PTO operation.*

### TURF TIGER Spreader Operating Components

The TURF TIGER spreaders are supplied standard with a **PTO shaft**, which is powered through the tractor drive train. The PTO powers the apron chain and the beater. For further information on engaging the PTO drive line, please refer to the following section, *Operating the TURF TIGER Spreader*.

The **standard adjustable metering endgate** is easy to open/close and adjust as needed for the desired spreading application.

### Guidelines for Loading the Spreader for Operation

- Maximum TURF TIGER payload is **3,000 pounds for Model 3100** and **3,750 pounds for Model 3200**.
- **ATTENTION:** NEVER store material in the spreader between unloading times during critical cold weather months when a frozen load could result in severe equipment damage (i.e. torn floor apron chain). DO NOT store wet material in the spreader (or keep the spreader outdoors with material in it)--doing so will accelerate rusting of the steel. Be aware that storing material in the spreader also makes the material difficult to unload (i.e. it may solidify/harden).

### Operating the TURF TIGER Spreader

**WARNING!** Before proceeding with operation of the spreader, review all safety statements as provided in Section 1 of this manual.



**WARNING:** To prevent serious personal injury, ensure that ALL safety shields are in place on the spreader before starting operation. NEVER operate the spreader without ALL safety shields in place.



**WARNING:** To prevent serious personal injury and/or equipment damage, DO NOT exceed 10 mph when transporting a loaded spreader.

1. Load the spreader according to the guidelines provided in this section.
2. Determine the desired opening of the adjustable metering endgate (up to 7 inches), according to the desired spreading application. Please refer to the **Recommended Settings** charts provided at the end of this section.

*(Procedure continued on the following page.)*

## Operating the TURF TIGER Spreader

3. Activate the PTO (this action may vary by tractor):  
**For newer tractors:** with the tractor at idle, simply activate the switch to engage the PTO.  
**ATTENTION: DO NOT engage the PTO while running at full throttle;** doing so may tear the front drive belt or cause it to jump off the pulley.  
**For older tractors:** With the tractor at idle, decompress the clutch and activate the tractor PTO lever. Release the clutch slowly so the PTO shaft will start the spreader paddles and apron chain.  
**NOTE:** To prevent "piling up" of material (or premature discharge) at initial startup, put the tractor in gear and begin forward motion immediately.
4. For best results, run the tractor throttle at the 540 rpm PTO shaft speed and regulate the ground speed to no more than 6 mph.
5. Observe the spreading application and determine if adjustments are required. If adjustments are desired, please refer to the following information for Adjusting the TURF TIGER. *The variables affecting the application rate are (a) tractor ground speed and (b) metering gate opening.*
6. When the spreader box is empty, stop the PTO by disengaging the lever/switch on the tractor and lower the endgate.
7. Refer to Section 4 in this manual for maintenance to be performed following operation of the spreader.

**IMPORTANT!** *Be aware that it may be necessary to re-tighten bolts after a few hours of initial operation -- watch and listen for any loose components. Be sure to check the wheel bolts for proper torque (75-80 ft. lbs.)*

**CAUTION:** When spreading sand, be sure to make a "dry run" every third load to allow accumulated sand to dislodge from the apron chain. Failure to do so will result in extreme tension in the chain, which may cause serious damage to the unit.

---

## Adjusting the TURF TIGER Spreader for Optimal Operation

### Adjusting Tractor Ground Speed

Using the tachometer on the tractor, select the tractor gear that will give you the desired ground speed (mph) with the engine speed delivering 540 RPM (PTO speed), which is required for all TURF TIGER spreader models. Ground speed can range from 2 to 8 mph, depending on the desired application rate.

### Adjusting the Metering Endgate

**The maximum opening for the metering endgate is 7 inches.** The recommended endgate setting for normal operation is 3 to 6 inches.

#### **To adjust the opening of the metering endgate:**

- Push down on the spring-loaded lever and HOLD.
- Use the handle on the metering gate to rotate the gate to the desired opening.
- Release the spring-loaded lever to lock the metering gate in the desired position.

## Recommended Settings for TURF TIGER Spreader Operation



**CAUTION:** For safe operation of the Turf Tiger spreader, DO NOT exceed the load capacities for the materials listed in the following charts/specifications. The maximum payload is **3,000 pounds for Model 3100** and **3,750 pounds for Model 3200**.

### Material Weights (Range Per Cubic Yard)

Spreader Model	Material	Material Consistency		Max. Weight	
		Dry	Wet	Max. Yds. (Wet)	
				Model 3100	Model 3200
Model 3100 or 3200 with Loading Flares (hauling 2-3 cubic yards)	Sand	2000 lbs./cu. yd.	2700 lbs./cu. yd.	1.1 cu. yd.	1.3 cu. yd.
	Topdress Mix (80% sand + 20% peat)	1600 lbs./cu. yd.	2200 lbs./cu. yd.	1.3 cu. yd.	1.7 cu. yd.
	Compost	900 lbs./cu. yd.	1800 lbs./cu. yd.	1.6 cu. yd.	2.0 cu. yd.
	Mulch	600 lbs./cu. yd.	1400 lbs./cu. yd.	2.1 cu. yd.	2.6 cu. yd.

### Material Volume Estimation

**Conversion Factors:**      One cubic yard = 27 cubic feet  
    One square yard = 9 square feet

**Estimation Formula:** Cubic yards of material required to cover a specified area

$$\begin{array}{ccccccc} \text{Area to cover} & \times & \text{Material} & \times & 0.0031 & = & \text{Cubic Yards of Material} \\ \text{(square feet)} & & \text{(depth in inches)} & & & & \text{Needed} \end{array}$$

Depth of Material	Quantity Needed to Cover	
	1,000 Square Feet	One Acre
1/8"	0.375 cubic yds.	17 cubic yds.
1/4"	0.75 cubic yds.	34 cubic yds.
1/2"	1.5 cubic yds.	67 cubic yds.
1"	3.0 cubic yds.	134 cubic yds.
2"	6.0 cubic yds.	269 cubic yds.
3"	9.0 cubic yds.	402 cubic yds.

**Example:** Determine the amount of material needed to cover 5,000 square feet with a 1/2" depth.

$$(5,000) \quad \times \quad (0.5 \text{ inches}) \quad \times \quad 0.0031 \quad = \quad 7.75 \text{ cubic yards}$$

## Recommended Settings for TURF TIGER Spreader Operation (continued)

### Initial Adjustments for the TURF TIGER Spreader (Sample Settings)

**Sample Application:** Sand with Saber Tooth™ Beater (approx. 10 ft. wide, variable depth)

Turf Tiger Adjustment	Saber Tooth Beater (10 ft. wide)		
	1/8" depth	1/4" depth	1/2" depth
<b>Ground Speed</b> (Approx. mph) (Approx. tractor gear)	6 mph (high range) (low gear)	4 mph (low range) (med. gear)	3 mph (low range) (low gear)
<b>Metering Gate Opening</b>	3"	5"	7"
<b>Tractor PTO</b> (Engine approx. 2000-2200 rpm)	540 rpm	540 rpm	540 rpm

**NOTE:** The settings provided in this chart will change with different materials. Fine tuning operation is best accomplished by varying the ground speed and selection of gears. Maintaining a PTO speed of 500-540 rpm will provide optimal spreading. Be aware that the gear selection may vary with different tractors.

## SECTION 4: MAINTENANCE & ADJUSTMENT

### Guidelines for Regular Maintenance



**WARNING:** All shields must be replaced after maintenance or adjustment procedures are performed. Failure to do so could result in serious personal injury or death.

Performing regular maintenance on the TURF TIGER Spreader will help ensure optimal performance. Please follow these guidelines for maintaining your spreader.

### General TURF TIGER Maintenance

- Clean the spreader once a week and before storing the unit for an extended period of time.  
**ATTENTION:** NEVER store material in the spreader between unloading times during critical cold weather months when a frozen load could result in severe equipment damage (i.e. torn floor apron chain). DO NOT store wet material in the spreader (or keep the spreader outdoors with material in it)--doing so will accelerate rusting of the steel. Be aware that storing material in the spreader also makes the material difficult to unload (i.e. it may solidify/harden).
- Check the spreader each time it is used for loose, bent, broken or missing parts.  
**ATTENTION:** During operation, listen for abnormal sounds which might indicate loose parts or other equipment damage. Correct any parts problems immediately; expanded parts views of all spreader assemblies are provided in the Appendixes at the back of this manual.  
**ATTENTION:** For safe and proper operation of the spreader, adhere to the following specifications for tightening the hitch hardware; failure to tighten all hitch hardware securely may result in equipment damage.

<u>Hardware</u>	<u>Torque Specification</u>
1/2"	60 ft. lbs.
3/8"	25 ft. lbs.
5/16"	15 ft. lbs.

- Check and grease the lube fitting at the PTO (at the front of the spreader) once a year. Remove the telescoping shaft, clean, and add a light coating of grease.
- Inspect the safety chain regularly to check the condition of the links and locking/hooking mechanisms; replace the chain as soon as weakness/breakage is noted.

**CAUTION:** When spreading sand, be sure to make a "dry run" every third load to allow accumulated sand to dislodge from the apron chain. Failure to do so will result in extreme tension in the chain, which may cause serious damage to the unit.

### Wheel/Tire Maintenance

- Once a month, check the wheel lug bolt torque. The recommended torque is 75-80 ft. lbs.
- Check the tires and maintain proper tire pressure:
  - 18 PSI for Turf Tires

**ATTENTION:** When storing the spreader for a period of time, block up the spreader to remove weight from the tires. Doing so helps to prevent any possible damage to the tires.



## Guidelines for Regular Maintenance (continued)

### Wheel Bearing Maintenance

- Adjust the wheel hub bearings after 100 loads and once each season thereafter.
    - Use a jack to raise the spreader to remove weight from the wheel.
-  **CAUTION:** Be sure to block up the spreader to prevent personal injury while working on the wheels.
- Rotate the wheel and torque the wheel hub bearings to 25 ft. lbs.
  - Back off the nut one flat, plus enough to install the cotter pin (1/6 turn min., 1/3 turn max.)

### Procedures for Spreader Adjustment

For optimal spreader functioning, Millcreek recommends that you periodically check the tension of the floor apron chain and the drive chains. Procedures for checking and adjusting these crucial operating components are provided in this section.

#### Checking and Adjusting the Floor Apron Chain

The **recommended floor apron chain tension** is achieved when the apron's lowest point is **4 to 4-1/2 inches below the frame** (behind the tire).

- Check the distance between the apron chain and the bottom of the side sheet at the apron's lowest point (just behind the wheels).
- If the distance is more than six (6) inches, the chain must be adjusted (tightened).

**Adjusting the floor apron chain** is accomplished by tightening the apron chain adjustment nuts on the spreader box (lower front left and right).

- Use a 9/16" wrench to tighten the adjustment nut on the lower left/right front of the spreader box as shown in Figure 4A.
- Observe the chain positioning with respect to the floor/apron.
- ***Make sure that the chains on each side of the apron are equally taut.***

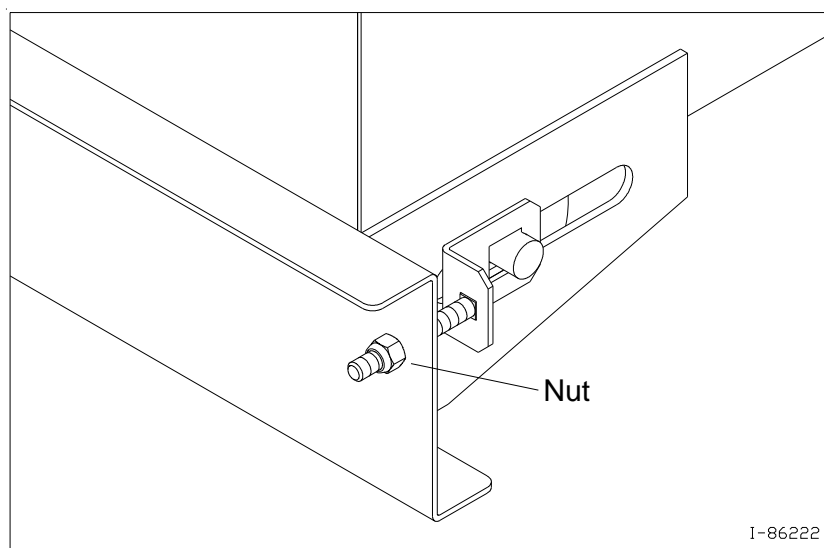

**Figure 4A - Adjusting the Floor Apron Chain for Proper Tension**

## Checking and Adjusting the Apron Drive Chains

**NOTE:** The apron drive chains are factory-set for the proper operating tension and should not require adjustment. The following instructions are provided for reference only, in rare cases where re-adjustment or replacement may become necessary.

**Refer to Figure 4B** for an illustration of the drive chains and related components. The chains should be snug, but not too tight. If the chains are too tight, they may cause excessive wear on the gearbox (resulting in premature failure). If the chains are too loose, they can slip and jump sprocket teeth when the spreader is operating with a full load.

**Check the drive chains in two positions**, at either the top or bottom span.

- When pushing on the middle of the span with one finger (about 20 lbs. pressure), the chain should deflect about 3/8 to 1/2 inch. A straight-edge ruler may be helpful in verifying the proper setting.
- If the chains do not show the proper deflection, they may need to be adjusted.

**Adjust the drive chains** according to the following guidelines. *Millcreek recommends that two people perform this procedure* (one to loosen/tighten the bolts, one to move and hold the bracket in position).

- Refer to Figure 4B. Adjust the **bracket position** by loosening the three 1/2" bracket bolts and sliding the bracket forward and/or backward as shown. Note that moving the bracket up and back increases the tension on both chains. *HINT: Using two pry bars to leverage the adjustment bracket (and two chains) for adjustment is helpful.*
- When you have achieved the desired tension on the drive chains, re-tighten the bolts on the adjustment bracket.

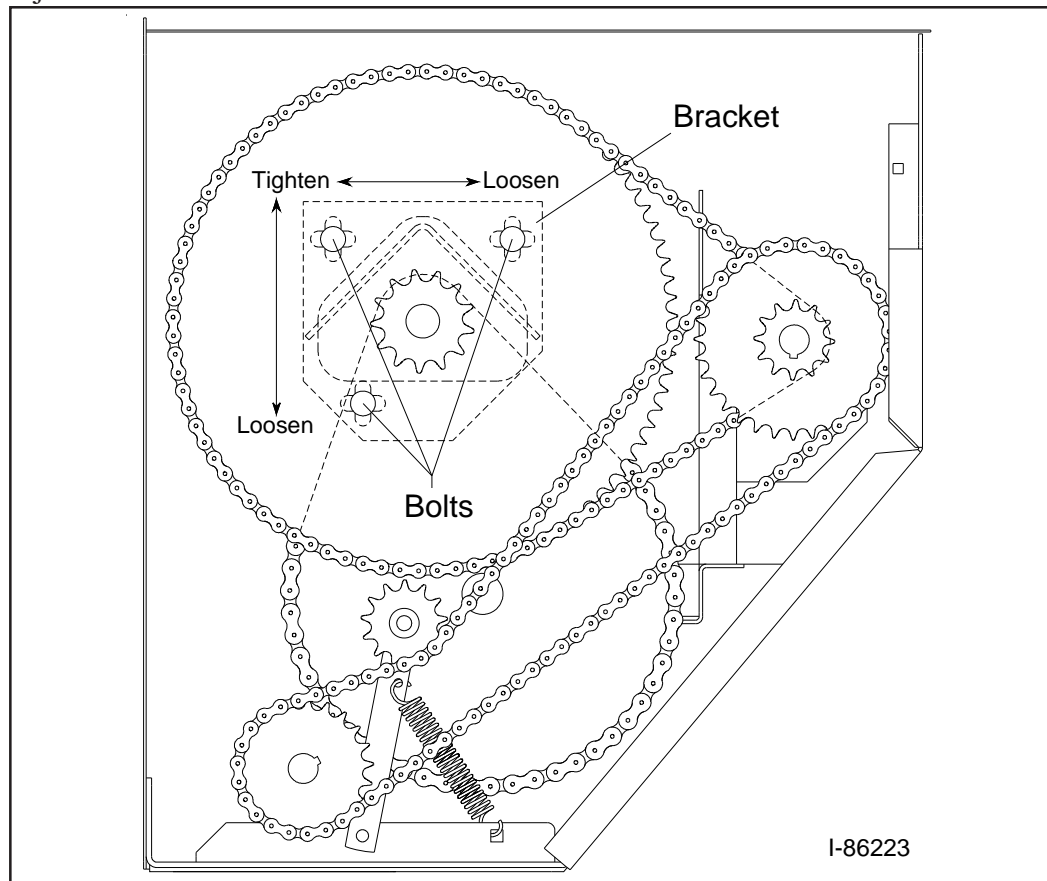

**Figure 4B - Adjusting the Drive Chains for Proper Tension**

## APPENDIX A: PARTS REFERENCE

The following information is provided for your reference in understanding how the TURF TIGER spreader is assembled and how spare parts can be identified and ordered properly.

### General TURF TIGER Spreader Specifications

	Model 3100	Model 3200
<b>Capacity, <i>struck</i>*</b>	25 cubic feet	34 cubic feet
<b>Capacity, <i>heaped</i></b>	50 cubic feet	62 cubic feet
<b>Capacity, <i>weight (payload)</i></b>	3000 lbs.	3750 lbs.
<b>Body Length</b>	89.5 inches	114 inches
<b>Body Width</b>	37 inches	37 inches
<b>Body Height</b>	17.5 inches	17.5 inches
<b>Overall Length</b>	11 feet	13 feet
<b>Overall Width</b>	70 inches	70 inches
<b>Overall Height</b>	51 inches	51 inches
<b>Loading Height</b>	43 inches	43 inches
<b>Construction</b>	All steel, poly floor	All steel, poly floor
<b>Apron Chain</b>	#67 steel detachable	#67 steel detachable
<b>Tires (18 psi)</b>	Turf tires (26.5x14x12, 4-ply)	Turf tires (26.5x14x12, 4-ply)
<b>Beater Bearings</b>	Sealed ball bearings	Sealed ball bearings
<b>Beater Drive</b>	Gear box	Gear box
<b>Apron Drive</b>	Gear box / Chain reduction	Gear box / Chain reduction
<b>Body Finish</b>	Powder coating	Powder coating
<b>Weight (with tires)</b>	1140 lbs.	1300 lbs.
<b>Tractor Weight and HP required**</b>	2000 lbs. and 25 HP & greater	2250 lbs. and 30 HP & greater

\*NOTE 1: Struck capacity is level to the top of the side sheets (does NOT include the loading flares).

\*\*NOTE 2: Tractor weight specifications for LEVEL terrain. For SLOPING terrain, increase tractor weight to 100% of load weight.







## Spreader Box/Hitch Assembly (continued)

<u>Item #</u>	<u>MC Part #</u>	<u>Qty.</u>	<u>Component Description</u>
1	34191	14	3/8 x 3/4 Carriage Bolt
2	34009	14	3/8 Flange Nut
3	261204	1	Left Hitch Bracket
4	215323	1	Jack Pin & Chain
5	215331	1	Jack Crank
6	261409	1	Right Front Hitch Bracket
7	215320	1	Complete Jack (includes items 25 & 26)
8	34112	2	1/2 x 1 Carriage Bolt
9	261408	1	Left Front Hitch Bracket
10	261404	1	Hitch
11	34384	4	1/2 Flange Nut
12	34085	2	1/2 x 1 Flange Bolt
13	34099	4	5/16 Flange Nut
14	261334	1	Axle
15	34274	4	5/16 x 3/4 Carriage Bolt
16	261207	1	Right Hitch Bracket
17	261432	1	Box 3100 TD
	261341	1	Box 3200 TD
18**	34311	1	1/2 x 1-1/4 Bolt
19	34227	1	1/2 Washer
20	261690	1	PTO Shaft Holder
21**	34198	1	1/2 Nylon Lock Nut
22	34057	1	5/16 Washer
23	34257	1	5/16 x 1-1/2 Bolt
24	220197	1	Ball Bungee

**\*\*NOTE:** The **PTO SHAFT HOLDER** must be able to **FOLD DOWN**; DO NOT overtighten the specified hardware (**item #'s 18, 21**). Millcreek recommends that you just tighten these hardware components, then loosen 1/4 turn to allow for proper movement.

## TURF TIGER Spreader Wheel/Hub Assembly

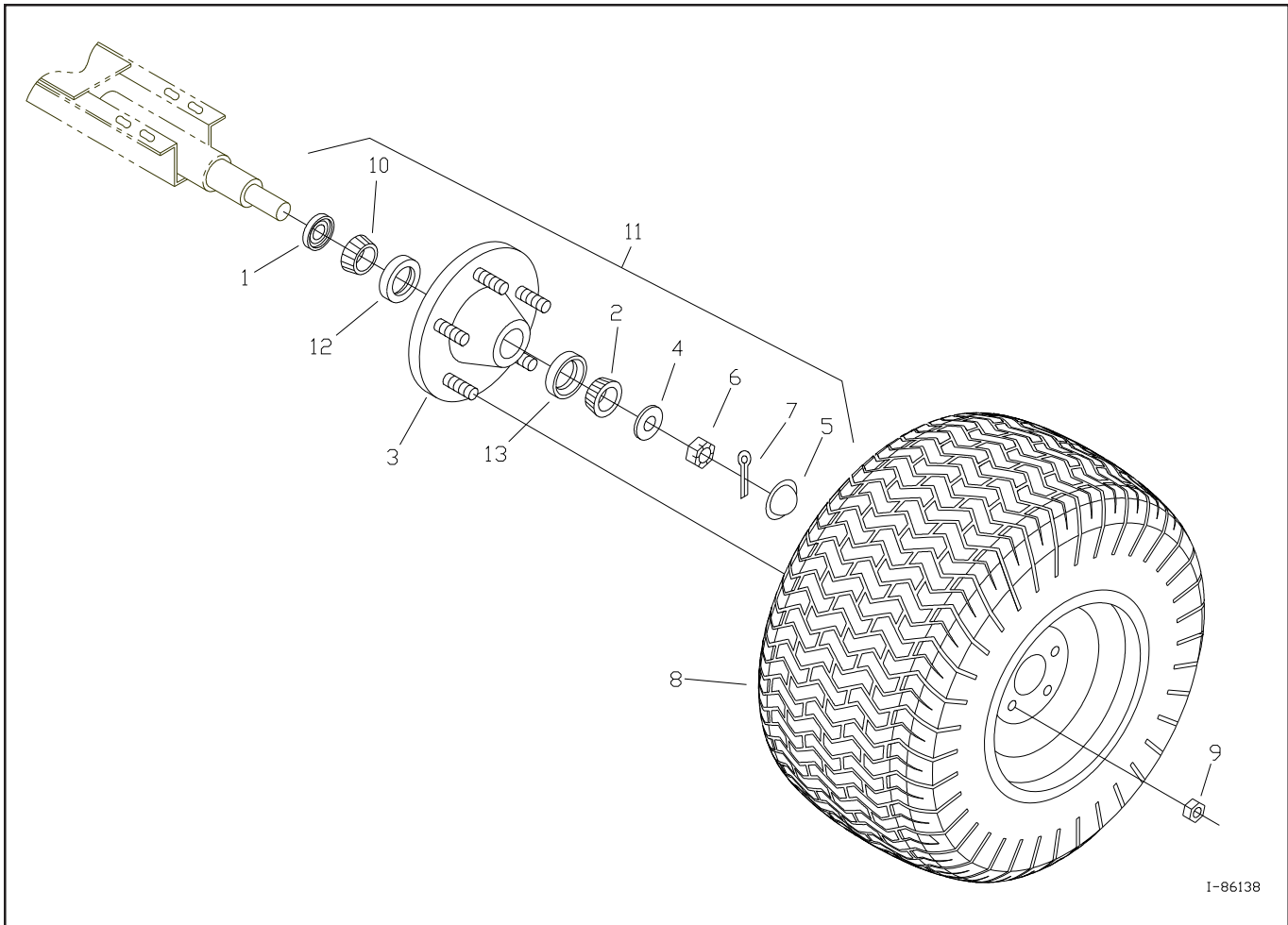

Figure A2 - Wheel/Hub Assembly Parts Detail



## Wheel/Hub Assembly (continued)

<u>Item #</u>	<u>MC Part #</u>	<u>Qty.</u>	<u>Component Description</u>
1	215248	2	Grease Seal
2	215251	2	Outer Bearing Cone
3	215250	2	Hub (includes items 12, 13)
4	215256	2	1" Washer
5	215253	2	Dust Cap
6	215252	2	Spindle Nut
7	34347	2	Cotter Pin
8	215138	2	Wheel and Tire
	215259	2	Rim
	215260	2	Tire
9	215255	10	Wheel Lug Nut
10	215249	2	Inner Bearing Cone
11	215221	2	Complete Hub (includes items 1-7, 9, 10)
12	215280	2	Inner Bearing Cup
13	215281	2	Outer Bearing Cup

# TURF TIGER Rear Drive Assembly

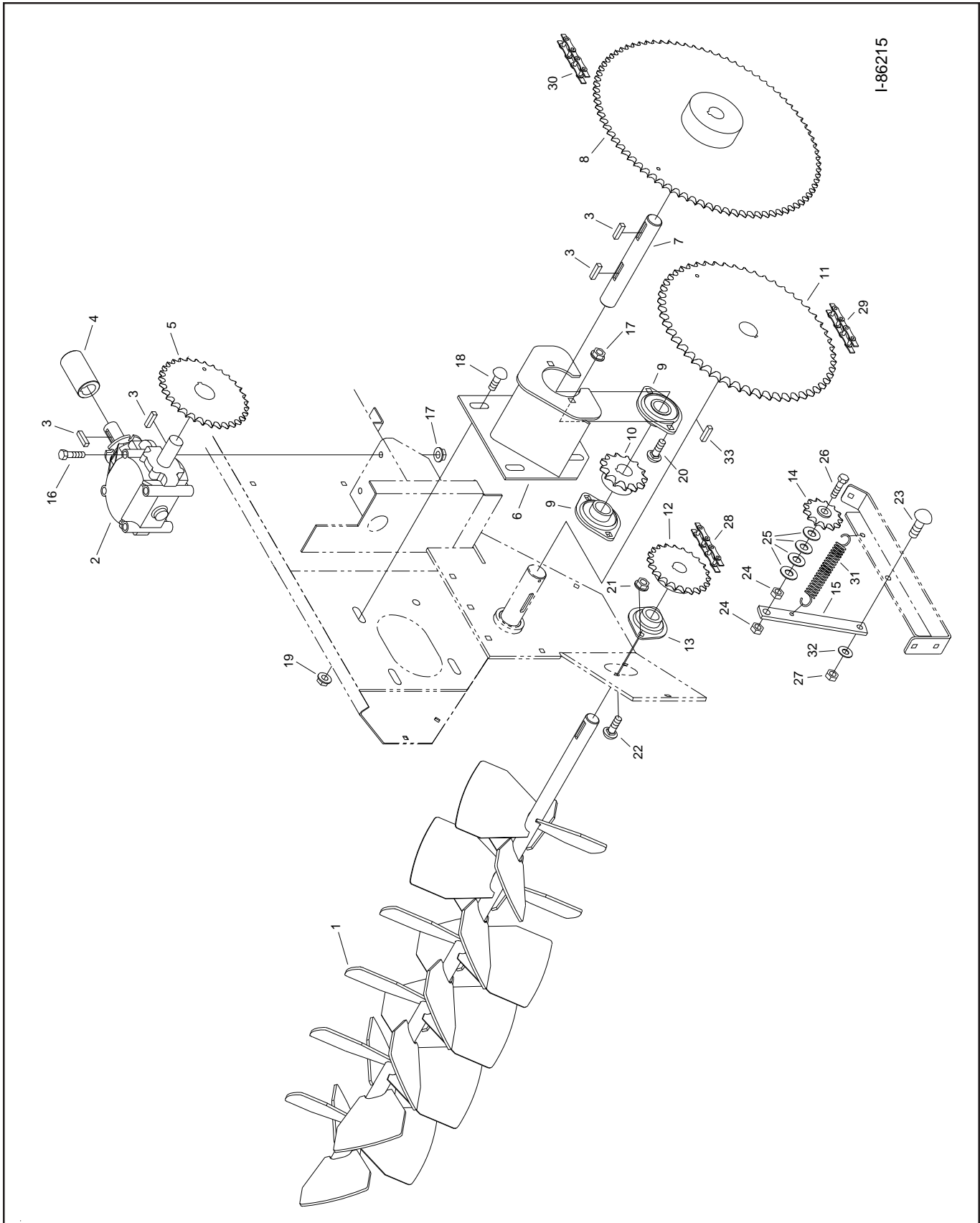

Figure A3 - Rear Drive Assembly Parts Detail

## Rear Drive Assembly (continued)

<u>Item #</u>	<u>MC Part #</u>	<u>Qty.</u>	<u>Component Description</u>
1	261330	1	Beater
2*	210174	1	Gearbox
3	210130	4	1/4 x 1 Key
4	220161	1	Coupler (includes 2 setscrews #34325)
5	210407	1	Double Sprocket 32 tooth & 12 tooth (includes 2 setscrews #34325)
6	261336	1	Jack Shaft Bracket
7	261340	1	Jack Shaft
8	210385	1	84 Tooth Sprocket (includes 2 setscrews #34325)
9	210227	2	1.125" Flanged Bearing (includes 2 setscrews #34325)
10	210380	1	13 Tooth Sprocket (includes 2 setscrews #34325)
11	210379	1	54 Tooth Sprocket (includes 2 setscrews #34325)
12	210389	1	22 Tooth Sprocket (includes 2 setscrews #34325)
13	210144	2	1" Flanged Bearing (includes 2 setscrews #34325)
14	210205	1	13 Tooth Idler Sprocket
15	261582	1	Idler Bracket
16	34241	4	3/8 x 4-1/2 Bolt
17	34009	8	3/8 Flange Nut
18	34112	3	1/2 x 1 Carriage Bolt
19	34384	3	1/2 Flange Nut
20	34191	4	3/8 x 3/4 Carriage Bolt
21	34099	4	5/16 Flange Nut
22	34274	4	5/16 x 3/4 Carriage Bolt
23**	34006	1	3/8 x 1 Carriage Bolt
24	34384	2	1/2 Flange Nut
25	34094	4	1/2 Washer
26	34271	1	1/2 x 2-1/2 Bolt
27**	34391	1	3/8 Center Lock Nut
28	210414	1	Chain #50RC x 98 Links (includes connector link #210284)
29	210415	1	Chain #60RC x 62 Links (includes connector link #210303)
30	210413	1	Chain #50RC x 94 Links (includes connector link #210284)
31	220138	1	Spring
32	34018	1	3/8 Washer
33	220176	1	5/16 x 1-1/2 Key

**\*NOTE:** This **GEARBOX** part number is for the **PTO** drive system, refer to **SECTION C** for **ENGINE DRIVE GEAR-BOX** part number.

**\*\*NOTE:** The **IDLER BRACKET** must be able to **ROTATE** to tension the chain; **DO NOT** overtighten the specified hardware (**item #'s 23, 27**). Millcreek recommends that you just tighten these hardware components, then loosen 1/4 turn to allow for proper movement.

# TURF TIGER Front Drive Assembly

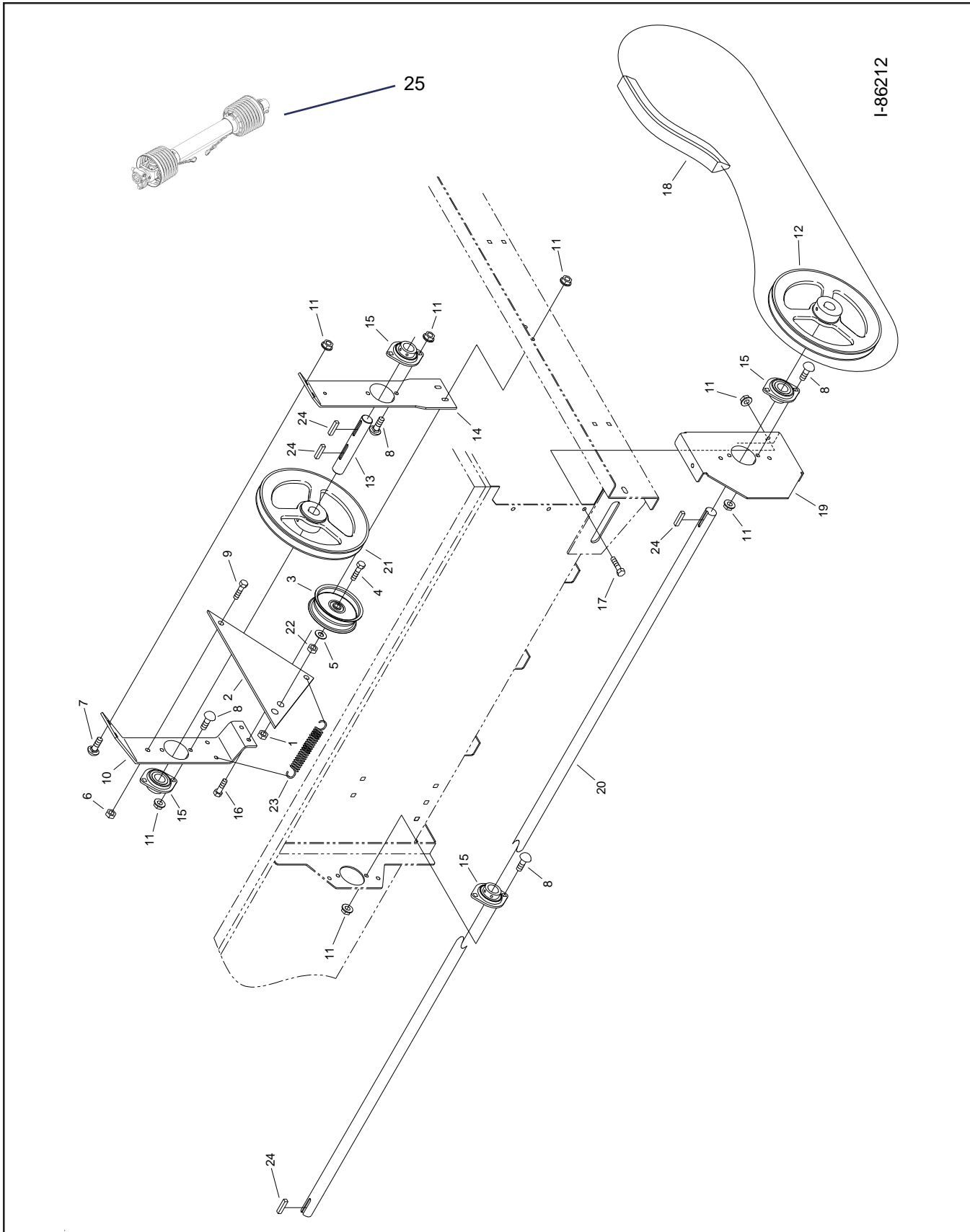

Figure A4 - Front Drive Assembly Parts Detail

## Front Drive Assembly (continued)

<u>Item #</u>	<u>MC Part #</u>	<u>Qty.</u>	<u>Component Description</u>
1	34384	1	1/2 Flange Nut
2	261594	1	Belt Idler Bracket
3	210200	1	Belt Tensioner
4	34254	1	1/2 x 2 Bolt
5	34227	1	1/2 Washer
6	34095	1	3/8 Stover Nut
7	34275	2	5/16 x 1 Carriage Bolt
8	34274	8	5/16 x 3/4 Carriage Bolt
9	34199	1	3/8 x 1 Bolt
10	261223	1	Rear PTO Shaft Bracket
11	34099	15	5/16 Flange Nut
12	210202	1	10" Belt Sheave (includes setscrew 34325)
13	261289	1	PTO Stub Shaft
14	261222	1	Front PTO Shaft Bracket
15	210144	4	1" 2-Flange Bearing
16	34336	2	5/16 x 1 Flange Bolt
17	34136	3	5/16 x 1/2 Flange Bolt
18	210419	1	Belt
19	261224	1	Front Drive Shaft Bracket
20	261234	1	Side Drive Shaft (3200)
	261387	1	Side Drive Shaft (3100)
21	210410	1	8.5" Belt Sheave (includes setscrew 34325)
22	34034	1	1/2 Nut
23	220138	1	Spring
24	210131	4	1/4 x 1-1/4 Key
25	210604	1	PTO Shaft (540 x 540)
	210164		PTO Shaft (540 x 1" Bore with Key)

\*\*Machines made 2016 and later will use  
210604

# TURF TIGER Apron Chain and Sprocket Assembly

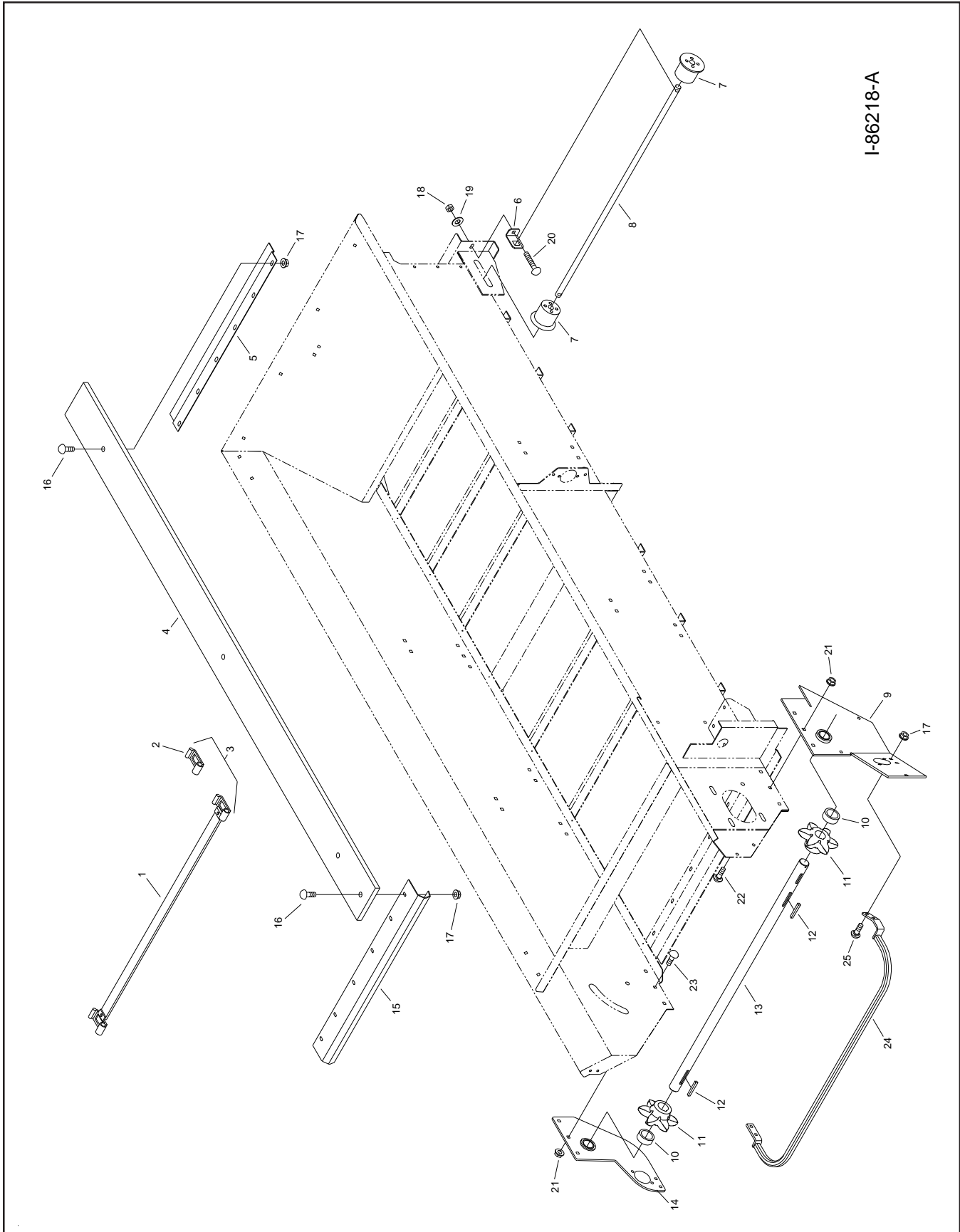

Figure A5 - Apron Chain and Sprocket Assembly Parts Detail

**Apron Chain Assembly (continued)**

<b>Item #</b>	<b>MC Part #</b>	<b>Qty.**</b>	<b>Component Description</b>
1	210437	33/44	Apron Slat (w/links welded)
2	210300	70/90	Apron Chain Link
3	210417	1	3100 Apron
	210416	1	3200 Apron
4	261481	6	3100 Floor Board
	261483	6	3200 Floor Board
5	260482	1/2	Poly Board Bracket
6	261587	2	Apron Tightener Bracket
7	220167	2	Plastic Idler
8	261465	1	Apron Idler Shaft
9	261447	1	Right Side Apron Shaft Bracket
10	261490	2	Spacer
11	210360	2	Apron Sprocket
12	220189	2	5/16 x 2 Key
13	261219	1	Apron Shaft
14	261325	1	Left Side Apron Shaft Bracket
15	261405	1	Apron Shaft Shield
16	34320	18/24	5/16 x 1-1/4 Carriage Bolt
17	34099	18/24	5/16 Flange Nut
18	34220	2	3/8 Nylon Stop Nut
19	34018	2	3/8 Washer
20	34324	2	3/8 x 5 Carriage Bolt
21	34009	6	3/8 Flange Nut
22	34006	3	3/8 x 1 Carriage Bolt
23	34191	3	3/8 x 3/4 Carriage Bolt
24	261663	1	Rear Guard Bar
25	34274	4	5/16 x 3/4 Carriage Bolt

**\*\*NOTE:** If two quantities are listed (e.g. 4/6), the first quantity applies for Model 3100, and the second applies for Model 3200.

## TURF TIGER Safety Shields and Guards

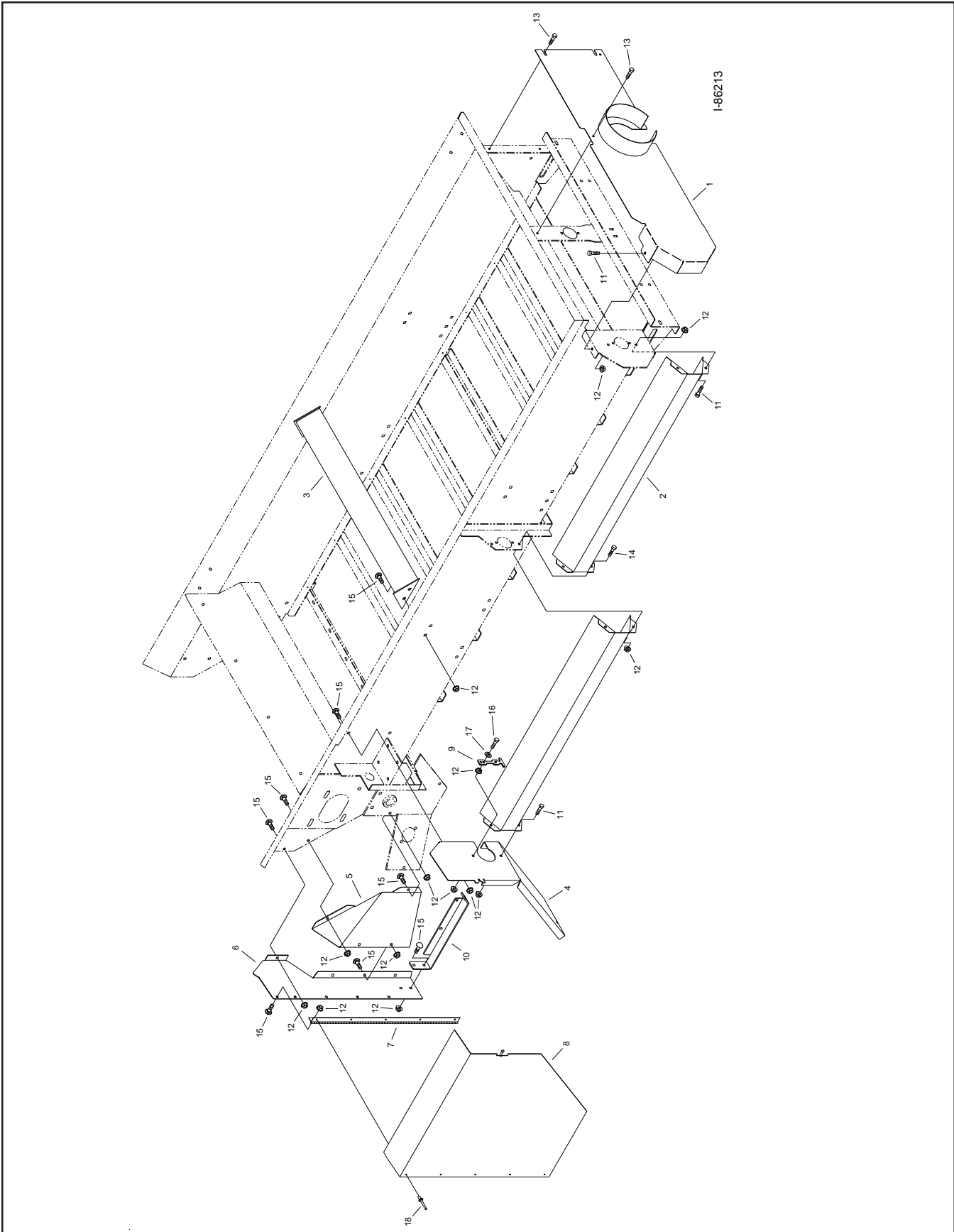

Figure A6 - Safety Shields and Guards Parts Detail



**Safety Shields and Guards (continued)**

<u>Item #</u>	<u>MC Part #</u>	<u>Qty.</u>	<u>Component Description</u>
1	261586	1	Front Shield
2	261388	1	Side Shield (3100)
	261236	2	Side Shield (3200)
3	261429	1/2	Load Baffle
4	261368	1	Gearbox Shield
5	261441	1	Deflector Shield
6	261370	1	Back Shield
7	270810	1	Hinge
8	261454	1	Rear Shield Door
9	220113	1	Rubber Latch
10	261581	1	Shield Brace
11	34136	5	5/16 x 1/2 Bolt
12	34099	28/34	5/16 Flange Nut
13	34118	3	5/16 x 3/4 Self Tapping Bolt
14	34328	0/2	5/16 x 3/4 Bolt
15	34337	21/25	5/16 x 1/2 Carriage Bolt
16	34222	1	5/16 x 1-1/4 Bolt
17	34057	1	5/16 Washer
18	34346	5	3/16 x 1/4 Pop Rivet

**\*\*NOTE:** If two quantities are listed (e.g. 4/6), the first quantity applies for Model 3100, and the second applies for Model 3200.

# TURF TIGER Metering Endgate Assembly

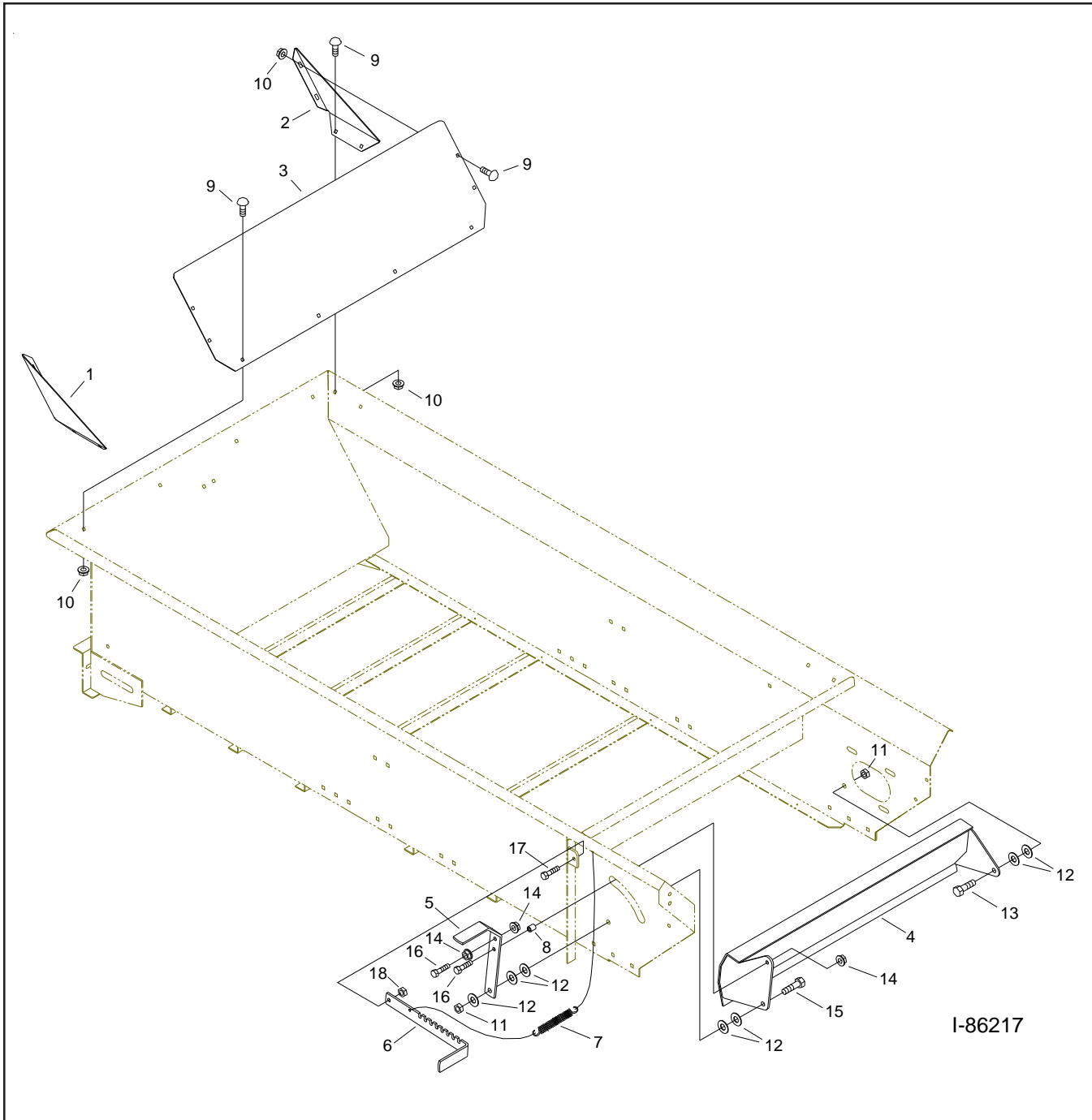

Figure A8 -Endgate Assembly Parts Detail

**Endgate Assembly (continued)**

<b><u>Item #</u></b>	<b><u>MC Part #</u></b>	<b><u>Qty.</u></b>	<b><u>Component Description</u></b>
1	261412	2	Flare Support FR, RL
2	261413	2	Flare Support RR, FL
3	261411	2	End Flare
4	261327	1	Metering Gate
5	261425	1	Metering Gate Handle
6	261426	1	Metering Gate Adjustment Lever
7	220171	1	Spring
8	261484	1	Spacer
9	34337	24	5/16 x 1/2 Carriage Bolt
10	34099	24	5/16 Flange Nut
11	34211	2	1/2 Nylon Lock Nut
12	34227	7	1/2 Washer
13	34311	1	1/2 x 1-1/4 Bolt
14	34009	3	3/8 Flange Nut
15	34254	1	1/2 x 2 Bolt
16	34252	2	3/8 x 1-3/4 Bolt
17	34199	1	3/8 x 1 Bolt
18	34095	1	3/8 Stover Lock Nut



## APPENDIX B: OPTIONAL PARTS REFERENCE

The following options are available for Model 3100 and 3200 TURF TIGER Spreaders. Please refer to the appropriate parts/assembly drawings provided in this Appendix. Some options come pre-assembled on the spreader from the factory; others may require assembly/installation. Please contact Millcreek for additional instructions as needed if the appropriate instructions have not been included with your shipment.

### Model 3100/3200 Spreader Options

- Safety Chain
- Pathmaker
- Slow Moving Vehicle Sign

### Safety Chain Assembly

**NOTE:** *The safety chain may be ordered as an optional component for the Model 3100/3200 Spreaders and is strongly recommended if the spreader is to be moved any time on a public roadway.*



**WARNING:** To prevent serious personal injury and/or equipment damage, DO NOT exceed 10 mph when transporting a loaded spreader.

1. Refer to Figure B1 for an illustration of the hook-up of the safety chain.
2. Attach the chain to the spreader hitch as shown, using the hardware provided (1/2-inch bolt, flat washer, lock nut).
3. Wrap the hook end of the chain around the tractor drawbar support or other structural member of the tractor frame and connect it as shown.



**WARNING:** For the safety chain to be effective, the installation of the chain should not allow more slack than is necessary for movement during spreader operation. Inspect the safety chain regularly to check the condition of the links and locking/hooking mechanisms; replace the chain as soon as weakness/breakage is noted.

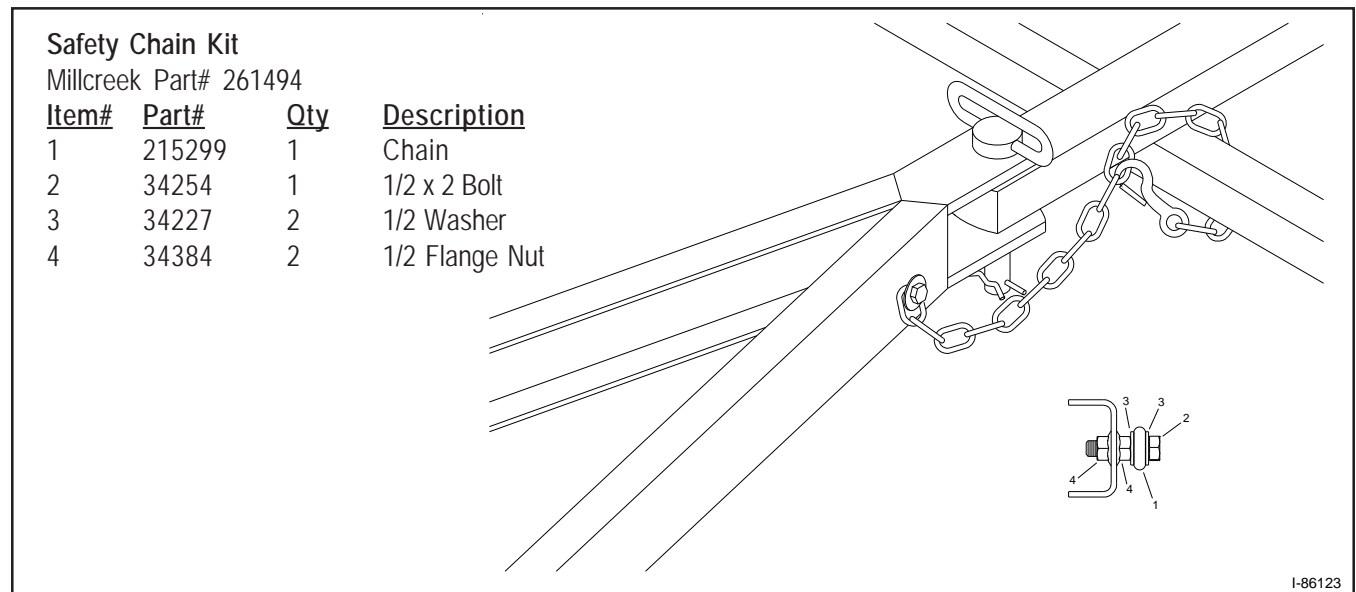

**Figure B1 - Attaching the Safety Chain**

## Pathmaker Assembly

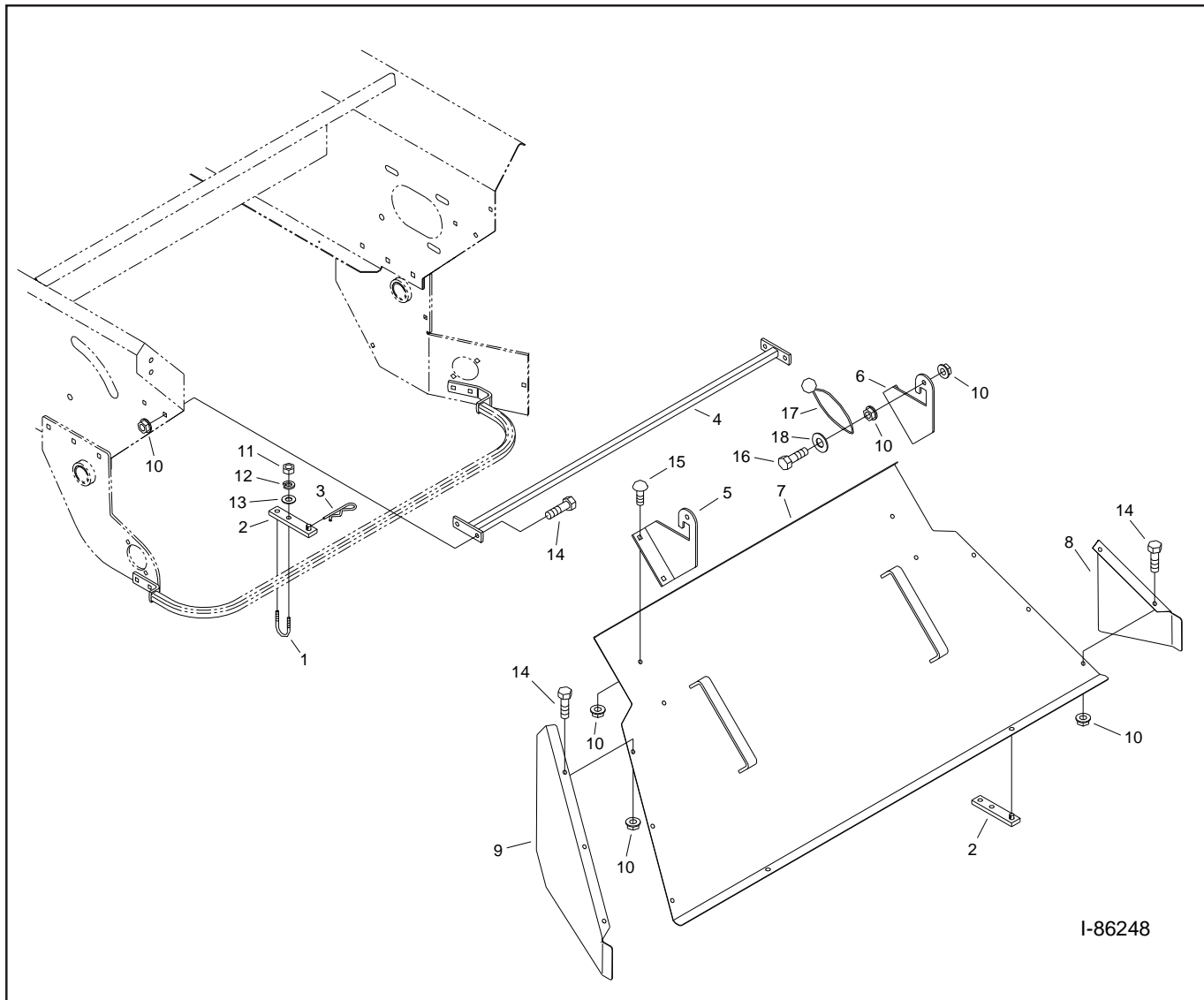

**Figure B2 - Pathmaker Attachment Parts Detail**

### Mounting the PathMaker

1. Refer to Figure B2 and the detailed parts list.
2. Bolt the Top Support Tube (#4) to the topdresser.
3. Loosely attach the U-bolt (#1) and Bottom Support (#2) around the topdresser's beater guard bar.
4. Bolt the Mounting Brackets and Sides (#'s 5,6,8, and 9) to the Top Deflector (#7) as shown.
5. Lift with handles (welded to part #7) to hook the Mounting Brackets (#5 and #6) over the Top Support Tube.
6. Slide the Bottom Supports (#2) to the proper location to get the pin through the hole in the Top Deflector (#7).
7. Insert the Clip Pin (#3) and tighten the hardware on the U-bolts.
8. Wrap the Ball Bungee (#17) around the top bar.

**Pathmaker Assembly (continued)**

<b><u>Item #</u></b>	<b><u>Part #</u></b>	<b><u>Qty</u></b>	<b><u>Description</u></b>
1	220119	2	U-Bolt
2	261810	2	Bottom Support
3	220143	2	Clip Hitch Pin #11
4	261707	1	Top Support Tube
5	261709	1	Left Side Mounting Bracket
6	261708	1	Right Side Mounting Bracket
7	261811	1	Top Deflector
8	261807	1	Right Side Pathmaker
9	261808	1	Left Side Pathmaker
10	34099	17	5/16 Flange Nut
11	34003	4	1/4 Nut
12	34235	4	1/4 Lock Washer
13	34052	4	1/4 Washer
14	34328	9	5/16 x 3/4 Flange Bolt
15	34274	4	5/16 x 3/4 Carriage Bolt
16	34257	2	5/16 x 1-1/2 Bolt
17	220197	2	Ball Bungee
18	34057	2	5/16 Washer

## Slow Moving Vehicle (SMV) Sign Assembly

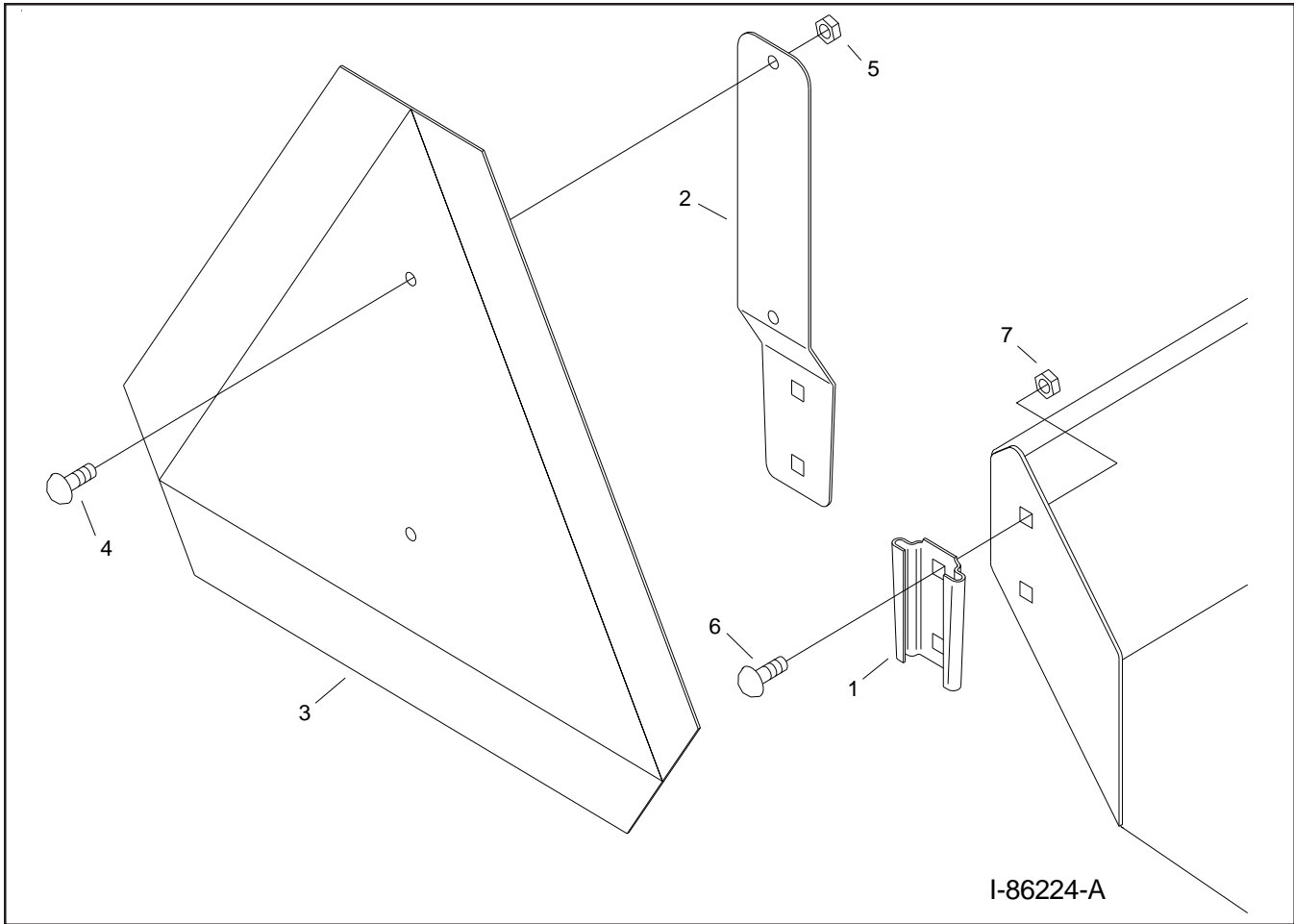

Figure B3 - SMV Sign Parts Detail

<u>Item #</u>	<u>MC Part #</u>	<u>Qty.</u>	<u>Component Description</u>
1	220185	1	SMV Mounting Socket
2	220186	1	SMV Spade Mount
3	220187	1	Reflective SMV with Metal Backing
4	34314	2	1/4 x 1/2 Carriage Bolt
5	34003	2	1/4 Nut
6	34282	2	5/16 x 1-1/2 Carriage Bolt
7	34020	2	5/16 Nut





---

## APPENDIX C: Engine Drive Information

### For Your Safety...

In addition to reviewing and following ALL safety statements as provided in the **Model 3100/3200 Operator's Manual**, also adhere to the following precautions for the safe operation of the Model 3100 Engine Drive topdresser.

 **WARNING:** Keep hands and feet from under the spreader at all times. Ensure that you are safely distanced from any other persons before operating the spreader.

 **WARNING:** To prevent serious personal injury and to promote safe spreader operation, keep all shields in place during operation. Ensure that all mounting hardware is properly tightened.

 **WARNING:** Ensure that the vehicle used to pull the Engine Drive Spreader is not only capable of safely towing the unit, but it can also provide sufficient braking power to stop the unit in a safe distance, even when going down a hill.

 **CAUTION:** Engine can reach high temperatures during normal operation.



**ATTENTION:** Be sure to review and follow the start-up and maintenance information in the Operator's Manual included with the engine.

---

## Operating the Model 3100 Engine Drive Topdresser

The operation of the Model 3100 Engine Drive topdresser is very similar to the operation of the Model 3100/3200 PTO-driven units. Refer to **Section 3, Operation & Adjustment**, in the **Millcreek Operator's Manual (MC Part# 43827)** for pertinent instructions, as well as the following procedure, which pertains specifically to the Engine Drive unit.



**WARNING! Before proceeding with operation of the topdresser, review all safety statements as provided in Section 1 of the Millcreek Operator's Manual, as well as in this bulletin and in the Engine Owner's Manual supplied with the unit.**



**WARNING:** To prevent serious personal injury, ensure that ALL safety shields are in place on the spreader before starting operation. NEVER operate the spreader without ALL safety shields in place.



**WARNING:** To prevent serious personal injury and/or equipment damage, DO NOT exceed 10 mph when transporting a loaded spreader.

1. Load the spreader according to the guidelines provided in the Millcreek Operator's Manual.
2. Determine the desired opening of the adjustable metering endgate (up to 7 inches), according to the desired spreading application. Please refer to the *Recommended Settings* charts provided in the Millcreek Operator's Manual.
3. Refer to the Owner's Manual provided with the engine for important detailed instructions.
4. Check the engine oil and fuel levels, and fill according to the instructions in the Engine Owner's Manual.
5. Start the engine according to the following sequence (summarized from the Engine Owner's Manual):
  - Move the fuel valve lever to the ON position.
  - To start a cold engine, move the choke lever to the CLOSED position.
  - Move the throttle lever away from the MIN. position to about 1/3 of the distance toward the MAX. position.
  - Turn the engine switch (key start) to the ON position.
  - Turn the engine switch (key start) to the START position, and hold it there until the engine starts. When the engine starts, release the key (allowing it to return to the ON position). If the engine fails to start within five (5) seconds, wait at least ten (10) seconds before turning the key start again.

**NOTE:** This engine model has also been supplied with a recoil starter, which may be used to start the engine instead of the key start.

  - If the choke lever has been moved to the CLOSED position (for a cold start), gradually move the lever to the OPEN position as the engine warms up.

---

## Operating the Model 3100 Engine Drive Topdresser (continued)

6. The Operating Switchbox (toggle switch) controls the action of the apron; this switch may be located with the operator at the towing vehicle for ease of use. After the engine has started, flip the operating switch to start the action of the apron in the topdresser (which moves the material towards the beater at the rear of the unit).
7. Observe the spreading application and determine if adjustments are required. If adjustments are desired, please refer to the information for **Adjusting the TURF TIGER** provided in the Millcreek Operator's Manual. *The variables affecting the application rate are (a) towing vehicle ground speed and (b) metering gate opening.*
8. When the topdresser box is empty, stop the apron by flipping the switch in the opposite direction.
9. Turn the engine off by moving the throttle lever to the MIN. position and turning the engine switch to the OFF position. Turn the fuel valve lever to the OFF position.
10. Refer to **Section 4** in the **Millcreek Operator's Manual** for maintenance to be performed following operation of the topdresser. Likewise, refer also to the **Engine Owner's Manual** for instructions pertaining to the periodic maintenance of the engine.

# Engine Mount and Drive System Assembly

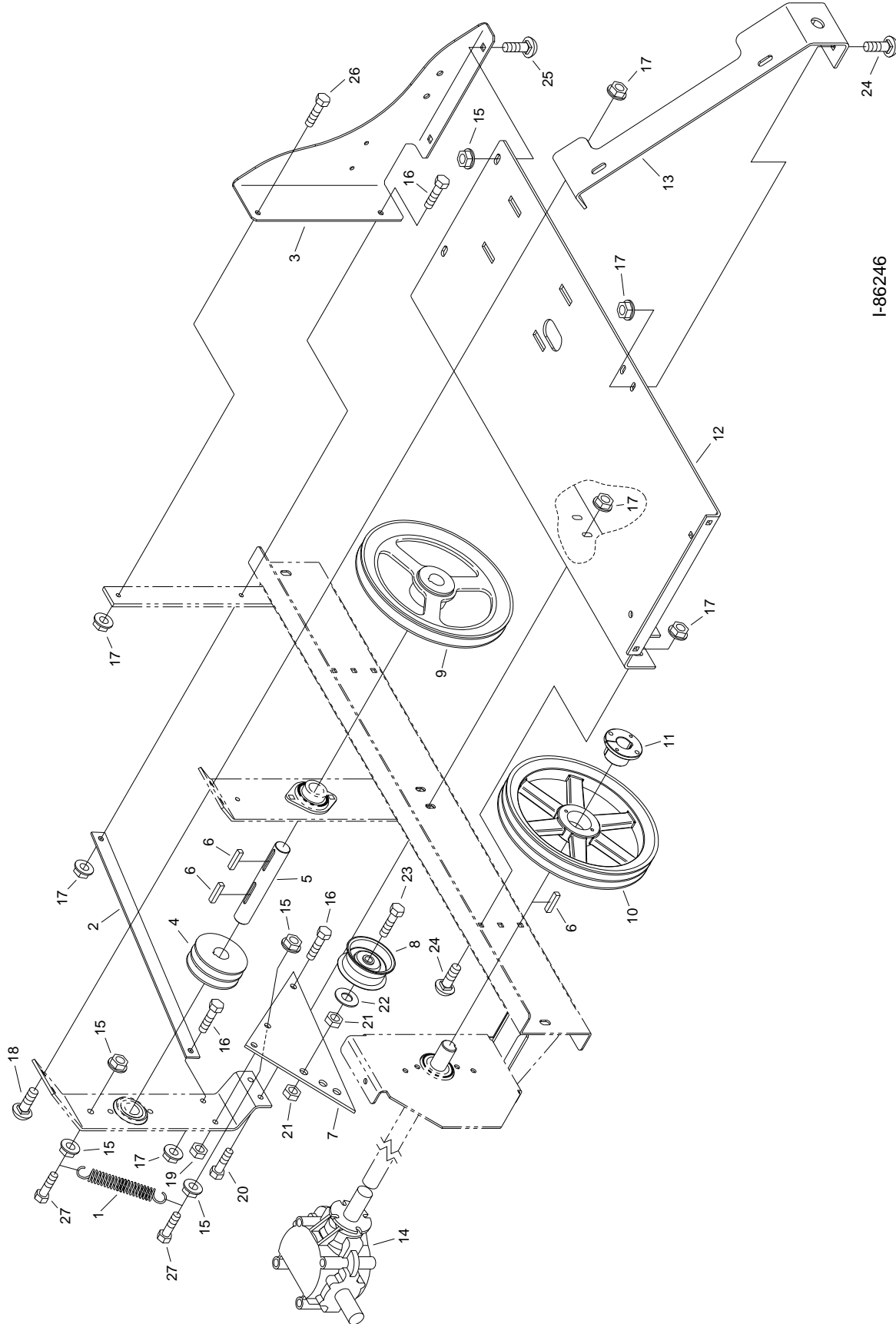

I-86246

Figure 1 - Engine Mount and Drive System

---

## Engine Mount and Drive System Assembly (continued)

<u>Item #</u>	<u>Part #</u>	<u>Qty</u>	<u>Component Description</u>
1	220138	1	Spring
2	261782	1	Jack Shaft Brace
3	261699	1	Left Support Bracket
4	210442	1	3-1/2" Double Pulley (includes 2 setscrews 34325)
5	261289	1	Jack Shaft
6	210131	3	1/4 x 1-1/4 Key
7	261594	1	Belt Idler Bracket
8	210200	1	Belt Tensioner
9	210202	1	10" Belt Sheave (includes setscrew 34325)
10	210443	1	10" Double Pulley
11	31226	1	Sheave Bushing
12	261698	1	Engine Mount Platform
13	261700	1	Center Support Bracket
14*	210162	1	Gearbox
15	34009	6	3/8 Flange Nut
16**	34336	3	5/16 x 1 Flange Bolt
17	34099	11	5/16 Flange Nut
18	34317	2	5/16 x 1-1/4 Carriage Bolt
19**	34072	1	5/16 Stover Locking Nut
20	34222	2	5/16 x 1-1/4 Bolt
21	34034	2	1/2 Nut
22	34094	1	1/2 Washer
23	34254	1	1/2 x 2 Bolt
24	34275	4	5/16 x 1 Carriage Bolt
25	34141	2	3/8 x 3/4 Carriage Bolt
26	34328	1	5/16 x 3/4 Flange Bolt
27	34224	2	3/8 x 1-1/4 Bolt

**\*NOTE:** This **GEARBOX** part number is for the **ENGINE DRIVE** system only; a different gearbox part number is specified for the PTO Drive units (please refer to Section A in the Operator's Manual).

**\*\*NOTE:** The **IDLER BRACKET** must be able to **ROTATE** to tension the belt; **DO NOT** overtighten the specified hardware (**item #'s 16, 19**). Millcreek recommends that you just tighten these hardware components, then loosen 1/4 turn to allow for proper movement.

# Engine and Safety Shields Assembly

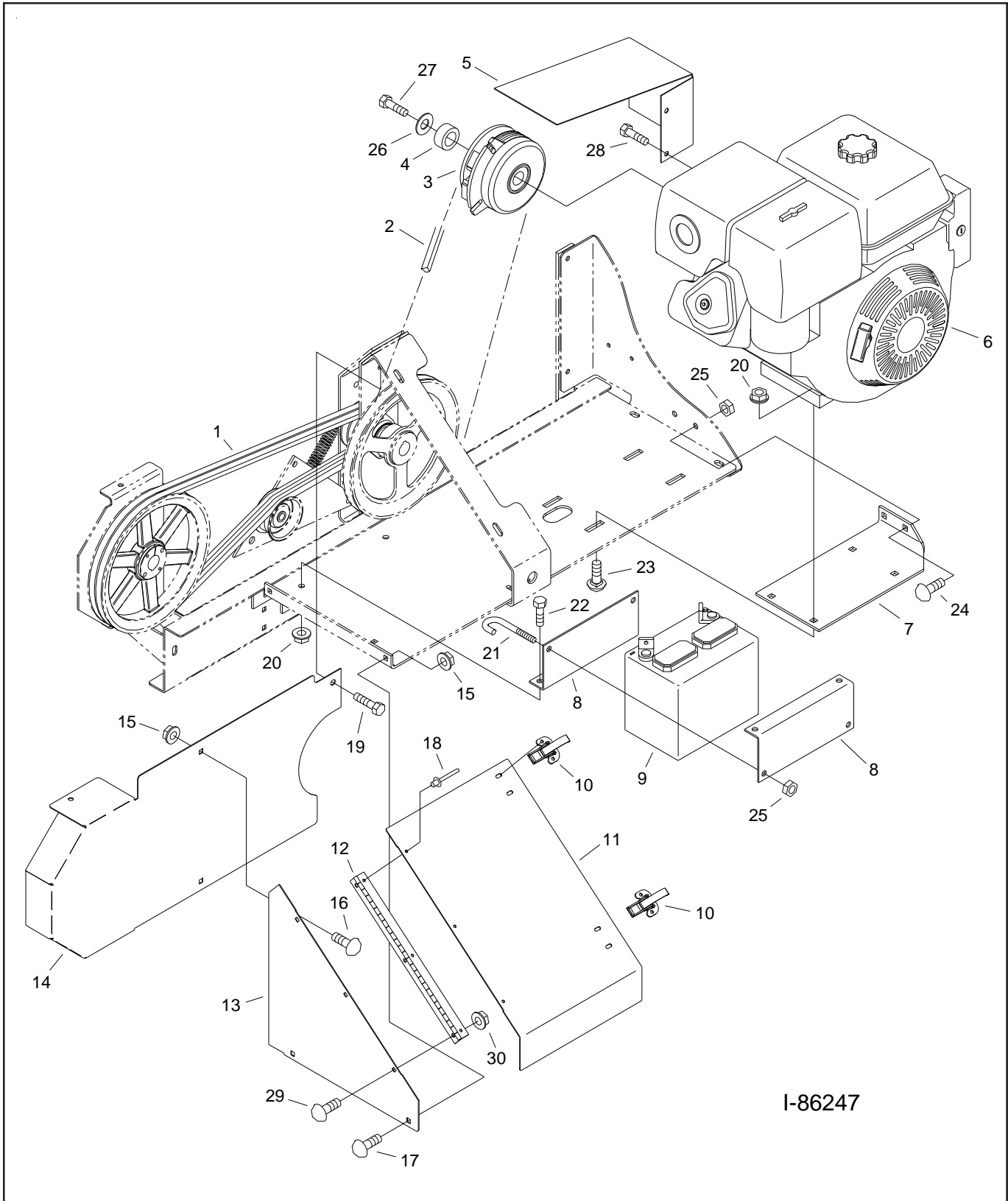

I-86247

Figure 2 - Engine and Safety Shields

---

## Engine and Safety Shields Assembly (continued)

<u>Item #</u>	<u>Part #</u>	<u>Qty</u>	<u>Description</u>
1	210446	2	Belt AX64
2	210450	1	Belt BX47
3	210448	1	Electric Clutch
4	261813	1	Spacer
5	261726	1	Belt Shield
6	210447	1	Engine
7	261715	1	Belt Tightener Bracket
8	261716	2	Battery Bracket
9	210449	1	Battery
10	220141	2	Latch (includes mounting hardware)
11	261719	1	Hinged Shield (includes item #'s 12 and 18)
12	270811	1	Hinge
13	261718	1	Side Shield
14	261717	1	Belt Shield
15	34099	4	5/16 Flange Nut
16	34337	2	5/16 x 1/2 Carriage Bolt
17	34274	2	5/16 x 3/4 Carriage Bolt
18	34346	3	1/4 x 3/16 Pop Rivet
19	34118	1	5/16 x 3/4 Self Tapping Bolt
20	34009	6	3/8 Flange Nut
21	260271	2	J-Bolt
22	34330	2	3/8 x 3/4 Flange Bolt
23	34422	4	3/8 x 1-3/4 Carriage Bolt
24	34218	2	3/8 x 1-1/2 Carriage Bolt
25	34220	4	3/8 Nylon Lock Nut
26	34373	1	Large 3/8 Washer
27	34408	1	3/8 x 1-1/4 Fine Thread Bolt
28	34343	2	5/16 x 1/2 Bolt
29	34236	3	1/4 x 3/4 Carriage Bolt
30	34092	3	1/4 Flange Nut

---

### How To Tighten the V-Belt (*Item #2 as shown*)

1. Using a 9/16" wrench, loosen the four 3/8" nuts that hold down the engine (#20).
2. Tighten the two 3/8" nuts (#25) on the right side of the engine until the desired belt tightness is obtained.
3. Re-tighten the four 3/8" nuts to fasten the engine.

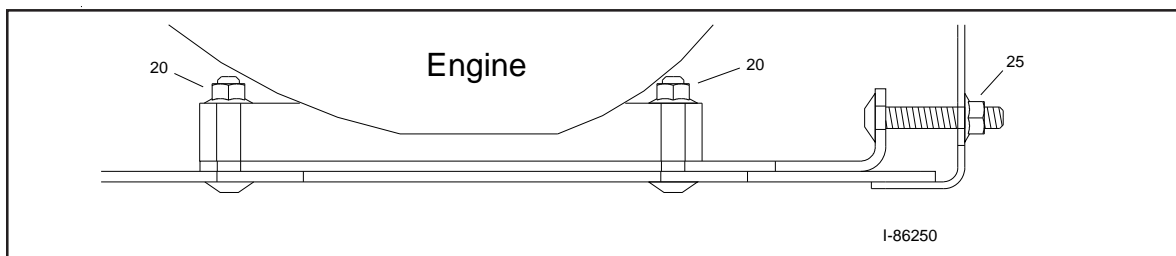

**Figure 3- V-Belt Tension Adjustment**

# Engine Drive Wire Sequence

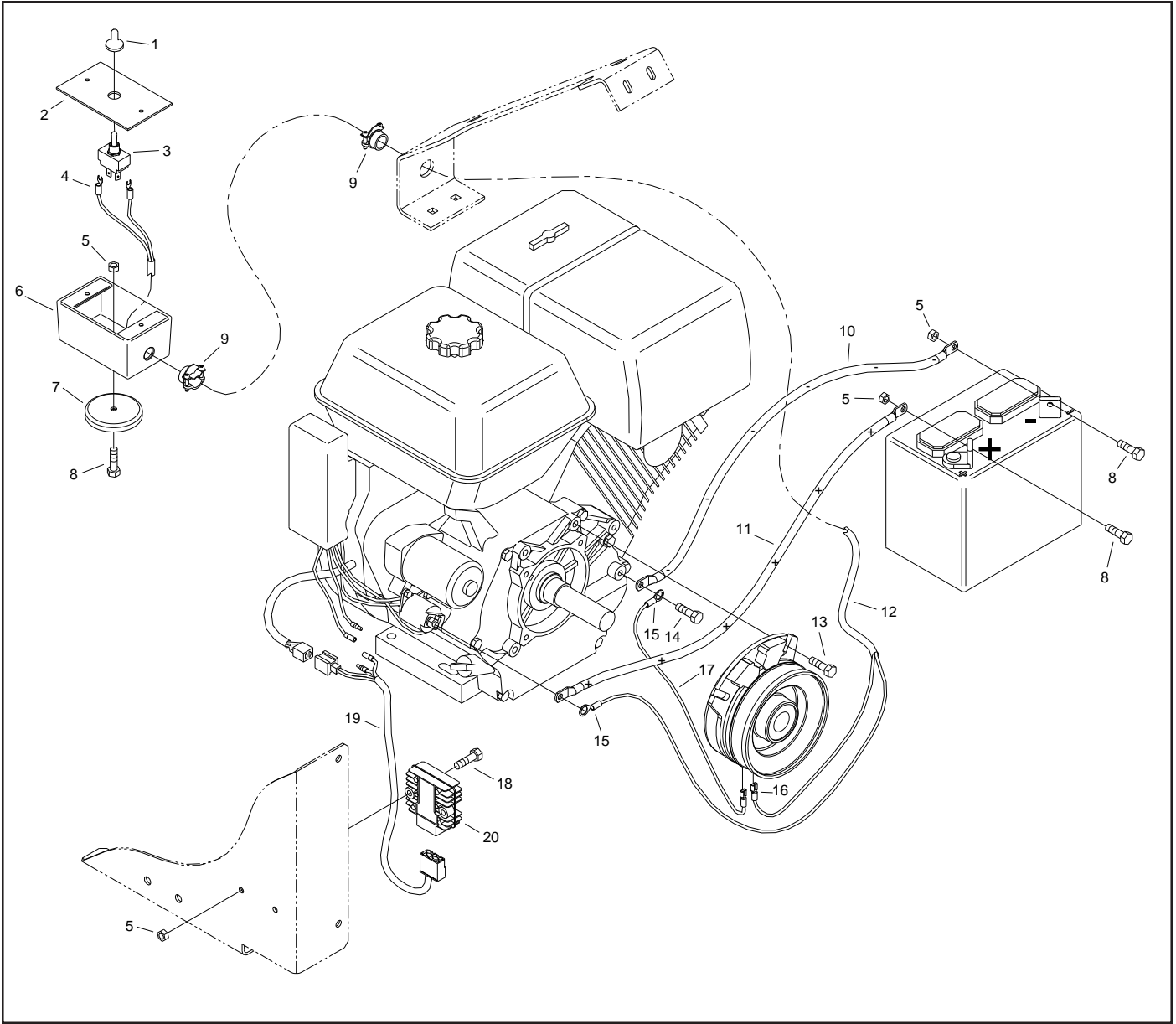

Figure 4 - Engine Drive Wire Sequence



---

## Engine Drive Wire Sequence (continued)

<u>Item #</u>	<u>Part #</u>	<u>Qty</u>	<u>Description</u>
1	33406	1	Switch Boot
2	261075	1	Receptacle Box Cover
3	33237	1	Switch
4	33380	2	Spade Terminal Connector
5	34124	5	1/4 Nylon Lock Nut
6	33401	1	Receptacle Box
7	220184	1	Magnet
8	34234	3	1/4 x 3/4 Bolt
9	33403	2	Box Connector
10	210452	1	Battery Wire Black 24"
11	210451	1	Battery Wire Red 38"
12	54134	216"	16/2 Wire
13	34242	1	3/8 x 2-1/2 Bolt
14	34343	1	5/16 x 1/2 Bolt
15	33408	2	3/8 Ring Terminal
16	33015	2	Female Spade Terminal
17	54019	12"	Black 16 ga Wire
18	34284	2	1/4 x 1-1/4 Bolt
19		1	Rectifier Wire (included with engine)
20		1	Rectifier (included with engine)

