

# OPERATOR'S MANUAL

## Commercial Aerators

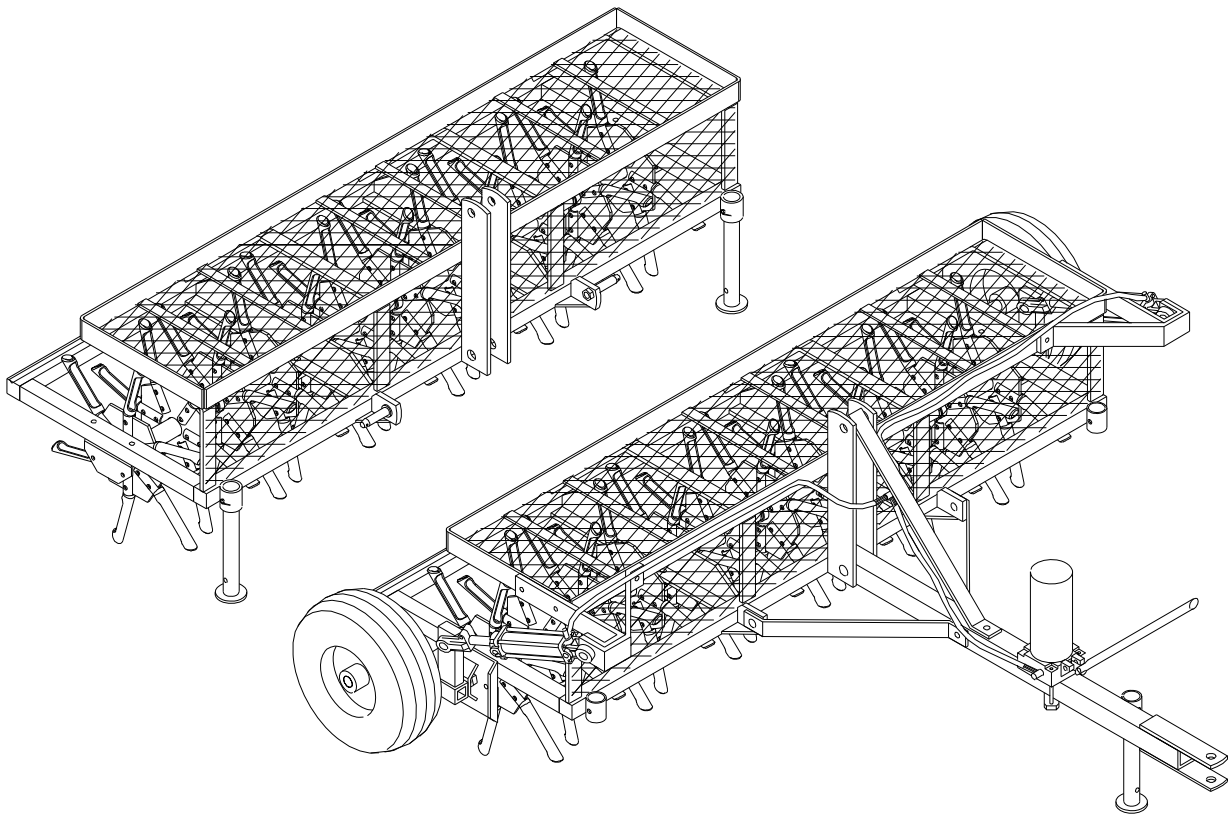

I-86023

PUBLICATION DATE: 11/12/12, Rev. 3

MILLCREEK PART # 43808

Millcreek Manufacturing Company  
525 Reservoir Rd  
Honey Brook PA 19344  
Phone: 800-311-1323



**WARNING: DO NOT assemble, operate, or maintain this equipment without first reading and understanding the information provided in this manual. Failure to follow all safety precautions as stated in the manual may result in serious personal injury or death.**

---

## WARRANTY INFORMATION

Millcreek Manufacturing Company (hereinafter called the Company) warrants to the original Purchaser, the Equipment, manufactured by the Company, to be free from defects in material and workmanship under normal use and service. The Company obligation under this Warranty shall be limited to replacement or repair of any parts thereof, free of charge, to the original Purchaser, at their place of business, provided, however, that the part(s) to be replaced or repaired, shall, within two years after delivery to the original Purchaser, be demonstrated to be defective; which determination shall be made by the Company. The said components or parts must be returned through the Selling Dealer or Distributor directly to the Company with all transportation charges prepaid. Notice of defect shall be furnished in writing to the Seller and to the agent through whom the machinery was purchased, disclosing in full all known defects and failure in operation and use. Reasonable time shall be given to the Seller to remedy any such defects and failures.

This Warranty does not cover, under any circumstances, any parts, components, or materials which, in the opinion of the Seller and the Company, have been subjected to neglect, misuse, alteration, accident, or repaired with parts other than those manufactured by and obtained from Millcreek Manufacturing Company.

This Warranty does not cover components which are already covered by a separate warranty provided by the supplier of said parts or components.

**This Warranty is made in lieu of all other warranties, expressed or implied, including any warranty of merchantability and fitness for use and purpose and of all other obligations or liabilities on the Company part and any implied warranty. The Company neither assumes nor authorizes any other person to assume for it, any other liability in connection with the sale of this equipment. This Warranty shall not apply to this equipment or to any part thereof which has been subjected to accident, negligence, alteration, abuse, or misuse.**

The Company makes no warranty whatsoever in respect to accessories or parts not supplied by the Company. The term "original Purchaser," as used in this Warranty, shall be deemed to mean that person for whom the equipment is originally supplied. This Warranty shall apply only within the boundaries of the continental United States.

Under this Warranty, the Company cannot guarantee that conditions existing beyond its control will not affect the Company's ability to obtain materials or manufacture necessary replacement parts.

The Company reserves the right to make design changes, or changes in specifications at any time, without any contingent obligation on the part of the Company to purchasers of machines and parts previously sold.

The Company warrants the construction of the equipment sold herein and will replace at the Company's expense for a period of two years from the date hereof, any parts which prove defective as determined under the terms of this Limited Warranty.

## TRADEMARKS

The Millcreek logo is a trademark of the Millcreek Manufacturing Company. All other brand or product names mentioned are the registered trademarks or trademarks of their respective owners.

## COPYRIGHT

Copyright © 2009 Millcreek Manufacturing Company. All rights reserved. No part of this publication may be reproduced, or distributed without the prior written permission of Millcreek Manufacturing Company, 525 Reservoir Road, Honey Brook, PA 19344. Subject to change without notice.



---

# TABLE OF CONTENTS

<b>SECTION 1: INTRODUCTION.....</b>	<b>1-1</b>
Guide to this Manual.....	1-1
For Your Safety.....	1-1
<b>SECTION 2: UNPACKING &amp; ASSEMBLY.....</b>	<b>2-1</b>
Removing the Shipping Crate.....	2-2
Assembling the Aerator.....	2-2
Connecting the Aerator to the Tractor.....	2-3
Standard 3-Point Hitch.....	2-3
Tow-Behind Hook-up.....	2-3
Warranty Registration.....	2-4
<b>SECTION 3: OPERATION.....</b>	<b>3-1</b>
Understanding Aerator Operation.....	3-1
Aerator Operating Conditions.....	3-1
Aerator Operating Guidelines.....	3-1
Special Operating Guidelines for Tow-Behind Models.....	3-1
<b>SECTION 4: MAINTENANCE.....</b>	<b>4-1</b>
Guidelines for Regular Maintenance.....	4-1
<b>APPENDIX A: PARTS REFERENCE.....</b>	<b>A-1</b>
General Aerator Specifications.....	A-1
Ordering Information.....	A-2
Commercial Aerator Component Parts Detail.....	A-2
Commercial Aerator: Slicing Blades Option.....	A-4
<b>APPENDIX B: TOW-BEHIND MODEL PARTS REFERENCE.....</b>	<b>B-1</b>

---

## SECTION 1: INTRODUCTION

### Guide to this Manual

This manual contains all the information necessary to safely assemble and operate the Millcreek Commercial Aerator. Consult the Table of Contents for a detailed list of topics covered. You'll find this manual's step-by-step procedures easy to follow and understand. Should questions arise, please contact your Millcreek dealer before starting any of the procedures in this manual.

**NOTE: Assembly and Operation procedures provided in this manual apply to all Commercial Aerator models, unless specifically noted otherwise.**

Regarding the information presented in this manual:

- All safety, operating, and servicing information reflects current production models at the time of publication of this manual.
- References made to left, right, front, and rear are those directions viewed when facing the unit from the rear.

**Please read all sections in the manual carefully--including the important safety information found in this section--before beginning any assembly/operation procedures; doing so ensures your safety and the optimal performance of your Millcreek Commercial Aerator.**

---

### For Your Safety...

For your safety, Millcreek documentation contains the following types of safety statements (listed here in order of increasing intensity):

- **NOTE:** A clarification of previous information or additional pertinent information.
- **ATTENTION:** A safety statement indicating that potential equipment damage may occur if instructions are not followed.



**CAUTION:** A safety statement that reminds of safety practices or directs attention to unsafe practices which could result in personal injury if proper precautions are not taken.



**WARNING:** A *strong* safety statement indicating that a hazard exists which can result in injury or death if proper precautions are not taken.



**DANGER!** *The utmost levels of safety must be observed;* an extreme hazard exists which would result in high probability of death or irreparable serious personal injury if proper precautions are not taken.

**The best operator is a careful operator.** By using common sense, observing general safety rules, and adhering to the precautions specific to the aerator, you, the operator, can promote safe equipment operation.

## For Your Safety... (continued)

In addition to observing the specific precautions listed throughout the manual, **the following general precautions apply and must be heeded to ensure proper, safe operation and to prevent injury to persons, pet or property.**



**WARNING:** Keep hands and feet away from the aerator at all times. Ensure that you are safely distanced from any other persons and pets before operating the aerator.



**WARNING:** DO NOT attempt to operate the aerator in areas with steep inclines, ditches, large rocks, stumps, or holes which may endanger the operator by upsetting the tractor or cause damage to the aerator.



**WARNING:** To avoid electrical shock hazards, DO NOT operate the aerator in areas where electrical wires may be embedded in the ground.



**WARNING:** Never clean, adjust, or repair the aerator while the tractor is moving.



**WARNING:** Never get off the tractor while it is in motion and/or while the aerator is in operation.



**WARNING:** Never wear loose clothing when operating the aerator as it may become caught in the moving parts of the machine.



**WARNING:** Never allow anyone to ride on the aerator or tractor.



**CAUTION:** To prevent injury and to promote safe equipment operation, keep all shields in place during operation. Ensure that all mounting hardware is properly tightened.

**ATTENTION:** To ensure proper and safe operation of the aerator, periodically inspect all parts for excessive wear. Replace worn components with factory-authorized parts.

The following safety decal(s) have been placed on your equipment to remind you of critical safety precautions which must be heeded to ensure the personal safety of you, the operator, and any persons in the vicinity of the equipment while it is in operation. Be sure to keep the safety decals clean and readable. If the decals ever become damaged or illegible, contact your Millcreek dealer for replacements.

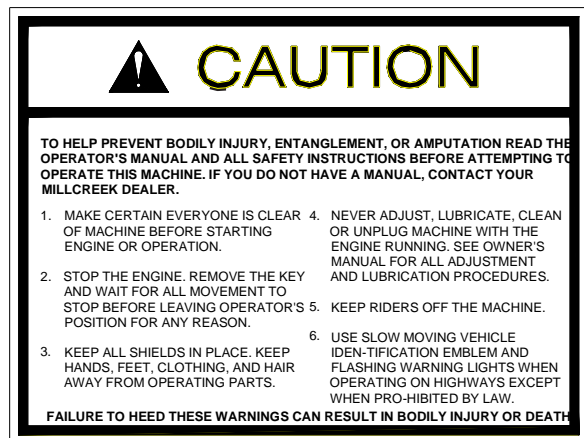

## SECTION 2: UNPACKING & ASSEMBLY

Unpacking involves removing the aerator coring spoon sections and welded frame from the shipping crate and inspecting the shipment. You may then assemble the aerator and hook it up to the tractor according to the procedures provided in this section. Detailed parts drawings are provided in the Appendixes at the back of this manual (for reference as needed).

**NOTE:** Depending upon the Millcreek Commercial Aerator Model ordered, you may have received two, three, four, or five sections of spoons as outlined in the following chart. The Model Number for each aerator also specifies the frame width. Figure 2A shows a typical welded frame and coring section.

<u>Model #</u>	<u>Number of Sections</u>	<u>Welded Frame Width</u>	<u>Coring Width</u>
420	2	42"	39"
630	3	63"	60"
840	4	84"	81"

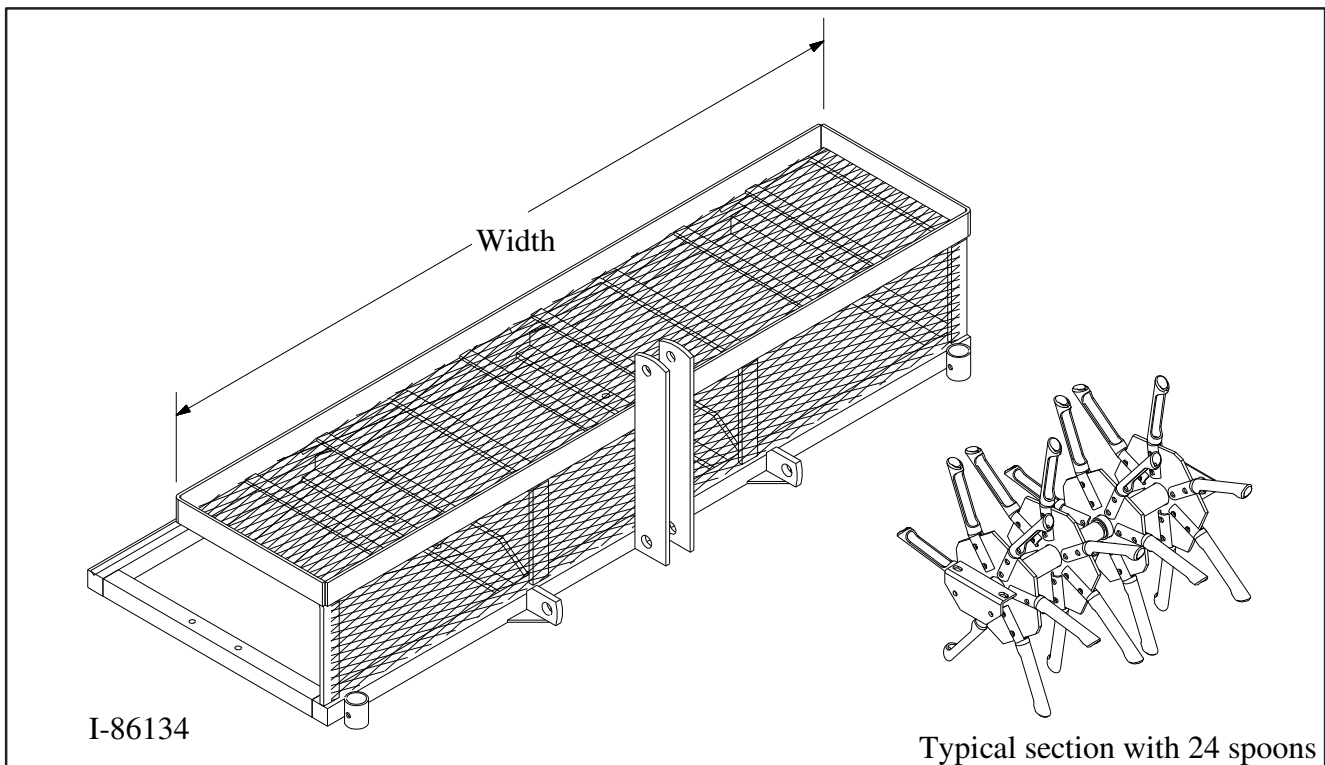

**Figure 2A - Commercial Aerator Welded Frame and Coring Spoon Section**

The following **optional components** may have also been included with your shipment (if ordered):

- Slicing Blades
- Tow-Behind Accessory Kit

Be sure to complete the **warranty registration** for the aerator following assembly/hook-up of the unit.

## Removing the Shipping Crate and Inspecting All Components

1. Carefully remove the top and sides of the wooden shipping crate. Locate the bag of hardware (for assembly) which is taped to one of the major components inside the crate.
  2. With the assistance of another person, carefully lift each section of coring spoons off the wooden pallet and set aside for assembly. Approximate weight of each section of spoons is 50 pounds.  
 **WARNING:** To prevent serious personal injury, wear heavy work gloves to protect your hands from the sharp coring spoons.
  3. With the assistance of another person, lift the welded frame off the wooden pallet and set aside with the three-point hitch side down on the ground. The approximate welded frame weight is: 200 lbs for Model 420, 250 lbs. for Model 630, and 300 lbs. for Model 840.  
**ATTENTION:** It is recommended that you place the frame on a mat or cardboard to protect it from scratches/damage.
  4. Inspect the aerator components to ensure that everything has been shipped to you in a satisfactory manner. Ensure that you have received the proper model and any options ordered. Immediately notify the freight company and your Millcreek dealer in case of shipping damage, shortage(s), and/or errors.
  5. Locate all safety decals and review their content.
- 

## Assembling the Aerator

**NOTE:** If you ordered a Commercial Aerator with the **Tow-Behind Hook-up option**, you may proceed directly to the following **Connecting the Aerator** procedure. The Tow-Behind models are supplied from the factory completely assembled.

Assembling the Commercial Aerator involves attaching each section of coring spoons to the welded frame as described in the following procedure.

 **WARNING:** To prevent serious personal injury, use great care in handling the sections of coring spoons; the edges of the spoons are very sharp. Wearing heavy work gloves is highly recommended.

1. Refer to the parts drawing in Appendix A at the back of the manual.
  2. If you have not already done so, place a mat or cardboard pieces on the ground where the assembly will take place. This will protect the finish on the aerator frame as you move it around.
  3. Position the aerator frame so the three-point hitch side is resting on the mat or cardboard.
  4. One by one, attach each section of coring spoons to the aerator welded frame according to the following steps (a) through (c). (Note that the spoons are factory assembled to the spool to form each section.)
    - (a) Use the 3/8" x 2-1/2" bolts to fasten the section brackets to the square tubing on the outside of the welded frame.
    - (b) Use the 3/8" x 1-1/2" bolts to fasten the section brackets to the mounting plate on the inside of the welded frame.
    - (c) After all sections have been assembled, tighten all hardware securely.
-

## Assembling the Aerator (continued)

5. When assembly is complete, carefully roll the aerator frame upright so the three-point hitch is pointing upward. (You will need to gain access to the retractable legs which are stored in the frame tubing.)
  6. Extend each of the aerator legs by removing the holding pin, extending the leg out to the desired height, and replacing the pin to hold it in position.
  7. The aerator is now ready for connecting to the tractor.
- 

## Connecting the Aerator to the Tractor

**NOTE:** Hooking up the aerator to the tractor may be accomplished in one of two ways, depending on the desired configuration and hardware ordered. Please refer to the appropriate instructions for your aerator model.

### Standard 3-point Hitch

1. Back the tractor into the hitch until the pins of the aerator hitch and tractor arms are lined up.
  2. Fasten the two tractor arms to the aerator pins and secure properly.
-  **WARNING:** Damage to the aerator or other vehicle, as well as injury to the operator, may occur if a properly-sized hitch pin is not installed as recommended.
3. Adjust the top three-point hitch arm and fasten the top link so that the aerator frame is sitting level on the ground.
  4. Raise the aerator with the three-point hitch of the tractor, and then retract the two aerator legs back into the aerator frame tubing.

### Tow-Behind Hook-up (Optional)

**NOTE:** The Tow-Behind models are completely factory-assembled (including spoon sections and hitch).

1. Back the tractor drawbar into the aerator drawbar hitch until the pin holes line up.  
**NOTE:** Depending upon the comparative heights of the aerator drawbar hitch and the tractor drawbar, it may be helpful to back the tractor so that its drawbar is positioned directly beside the aerator drawbar hitch. Then, as necessary, lift up and/or swing the aerator drawbar hitch over the tractor drawbar to align the pin holes.
2. Install the hitch pin to hold the hitch securely.

**IMPORTANT NOTE:** Following assembly of all aerator components (including any optional components), check for proper assembly and adjustment at all points. Make sure that all bolts are tightened securely. Be aware that it may be necessary to re-tighten bolts after a few hours of initial operation; doing so helps to ensure safe and proper operation of the aerator.



## Warranty Registration

For proper warranty registration, Millcreek requires that you fill out the provided warranty registration card and return it *within 30 days* to:

MILLCREEK WARRANTY REGISTRATION  
Millcreek Manufacturing Company  
525 Reservoir Rd  
Honey Brook PA 19344

**IMPORTANT NOTE: The Model Number and Serial Number of the aerator are located on the side of the aerator frame. When calling for warranty or service, please provide the Model Number and Serial Number.**

## SECTION 3: OPERATION

### Understanding Aerator Operation

Proper and safe operation of the Millcreek Commercial Aerator requires: (1) understanding the conditions necessary for optimal aerator operation and (2) heeding all safety precautions as stated in this manual, as well as operating guidelines provided in this section.

### Aerator Operating Conditions

Normal (and desired) operating conditions should allow the 3/4" diameter coring spoons to penetrate the soil and pull soil cores approximately three inches long. Factors contributing directly to this function (i.e. penetration of the coring spoons) include: **WEIGHT** of the aerator, **MOISTURE** of the soil, and **SOIL TYPE**. Obviously, when the soil has a high concentration of moisture, the penetration of the spoons will be easy and effective. But, when the soil is hard-packed and/or dry, weight will need to be added to achieve sufficient penetration.

Millcreek provides 1/2" thick steel plates that can be mounted into the aerator frame to provide additional weight when needed. The **optional Weight Packages** for each aerator model are detailed in the following chart.

<u>Model</u>	<u>Total Weight</u>	<u>Number of Plates</u>	<u>Weight Per Plate</u>
420	280 lbs.	8	35 lbs.
630	440 lbs.	8	55 lbs.
840	560 lbs.	8	70 lbs.

### Aerator Operating Guidelines

- Ensure that the aerator legs have been raised sufficiently for operation.
- Make sure the tractor three-point hitch lift arms are positioned low enough to allow the aerator to penetrate the soil properly.
- Lower the aerator into the ground while traveling forward.  
**NOTE:** Recommended operating speed for optimal ground penetration is **3-6 mph**.
- Sharp turns should be avoided to prevent excessive slicing of the ground/lawn surface.

### Special Operating Guidelines for Tow-Behind Models

Tow-Behind aerator models are supplied with a hand pump for use in raising and lowering the aerator as needed for operation. (Refer to Appendix B for a detailed parts drawing of the Tow-Behind model.)

**To Raise the Aerator:** Turn the lever on the hand pump **counterclockwise** and pump up to raise the aerator.

**To Lower the Aerator:** Turn the lever on the hand pump **clockwise** to release pressure from the pump, which in turn will lower the aerator.



## SECTION 4: MAINTENANCE

### Guidelines for Regular Maintenance



**WARNING:** All shields must be replaced after maintenance procedures are performed. Failure to do so could result in serious personal injury or death.



**CAUTION:** When performing maintenance procedures on the aerator, be aware that the aerator coring spoons are extremely sharp. **Wearing heavy work gloves is strongly recommended.**

Performing regular maintenance on you Millcreek Commercial Aerator will help ensure optimal performance. Please follow these guidelines for maintaining your aerator:

- Clean the aerator after each use. Removing mud and thatch from the spoons after each use will help ensure optimal performance. Plugged spoons may not function properly.
- Check the aerator each time it is used for loose, bent, broken or missing parts.  
**ATTENTION:** During operation, listen for abnormal sounds which might indicate loose parts or other equipment damage. Correct any parts problems immediately; expanded parts views of all aerator assemblies are provided in the Appendixes at the back of this manual.
- Check the spoons after each use to ensure that no foreign objects (e.g. wire, weeds, etc.) are wrapped around them.
- Grease all lube fittings every 10 hours.

**ATTENTION:** All lube fittings are SAE standard. Pump lubricant into the fitting(s) until grease begins to seep from the bearing.

**DO NOT** lubricate or oil the bushings for the aerator shaft-- they are oil impregnated. (Oil will collect dust and dirt, causing the bushing to wear faster.)

**Worn grease fittings that will not hold the gun and/or fittings with a stuck check ball must be replaced.**

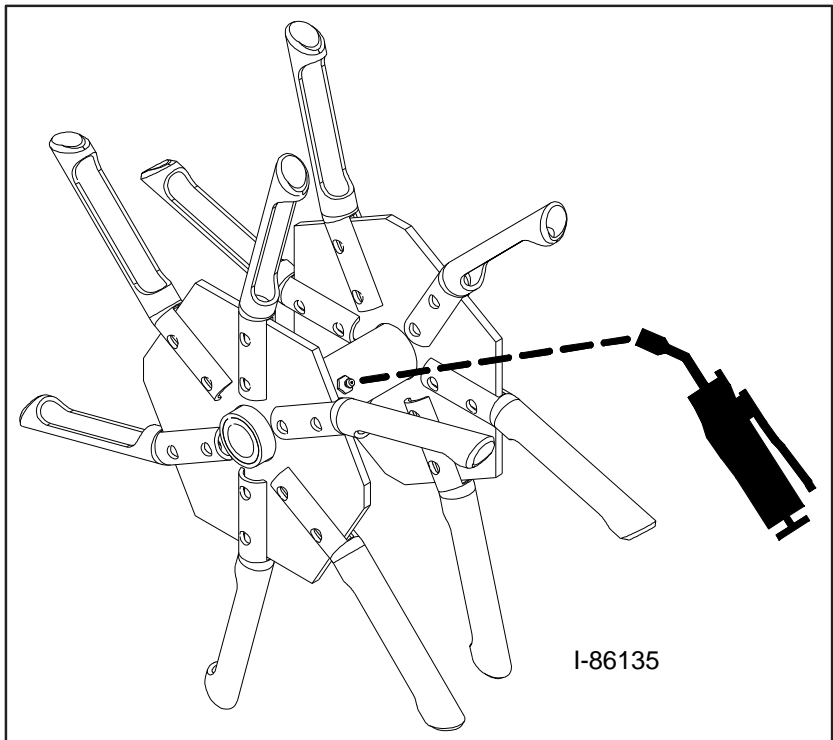

**Figure 4A - Location of Lube Fittings (per section) on the Commercial Aerator**

## APPENDIX A: PARTS REFERENCE

The following information is provided for your reference in understanding how the Millcreek Commercial Aerator is assembled and how spare parts can be identified and ordered properly.

### General Aerator Specifications

<b>Construction</b>	Welded steel, 1-1/2" x 1-1/2" solid square bar
<b>Available Hitches</b>	Category 1, three-point (standard) Tow-behind drawbar
<b>Main Shaft</b>	1" diameter
<b>Aerating Wheels</b>	All-steel construction, temper-hardened spoons
<b>Spoon Wheel Bearings</b>	Oil-impregnated for longer life
<b>Coring Spoons</b>	3/4" closed standard; 6 spoons per wheel
<b>Coring Depth</b>	Up to 4", depending on soil conditions
<b>Protector Shield</b>	Heavy steel mesh, standard on all models

### Specifications Per Model

	<b>Model 420</b>	<b>Model 630</b>	<b>Model 840</b>
<b>Height</b>	24"	24"	24"
<b>Length</b>	23-1/2"	23-1/2"	23-1/2"
<b>Width</b>	42"	63"	84"
<b>Weight*</b>	300 lbs.	410 lbs.	480 lbs.
<b>Coring Width</b>	39"	60"	81"
<b>Number of Spoon Wheels (per model)</b>	8	12	16
<b>Number of Spoons (per model)</b>	48	72	96
<b>Coring Pattern</b>	5" x 9-1/2"	5" x 9-1/2"	5" x 9-1/2"

\*NOTE: Three-point hitch must have 500 lb. lifting capacity. DO NOT exceed the tractor manufacturer's recommended lifting capacity.

### Ordering Information

When ordering replacement parts, please provide the following information to your local Millcreek dealer:

- Model and Serial Number of the unit
- Part Number and Description as it appears on the following drawings/parts lists

## Commercial Aerator Component Parts Detail (Standard Three-Point Hitch Models)

**NOTE:** Coring spoons are supplied as standard. Slicing blades (Figure A2) may be ordered as an option.

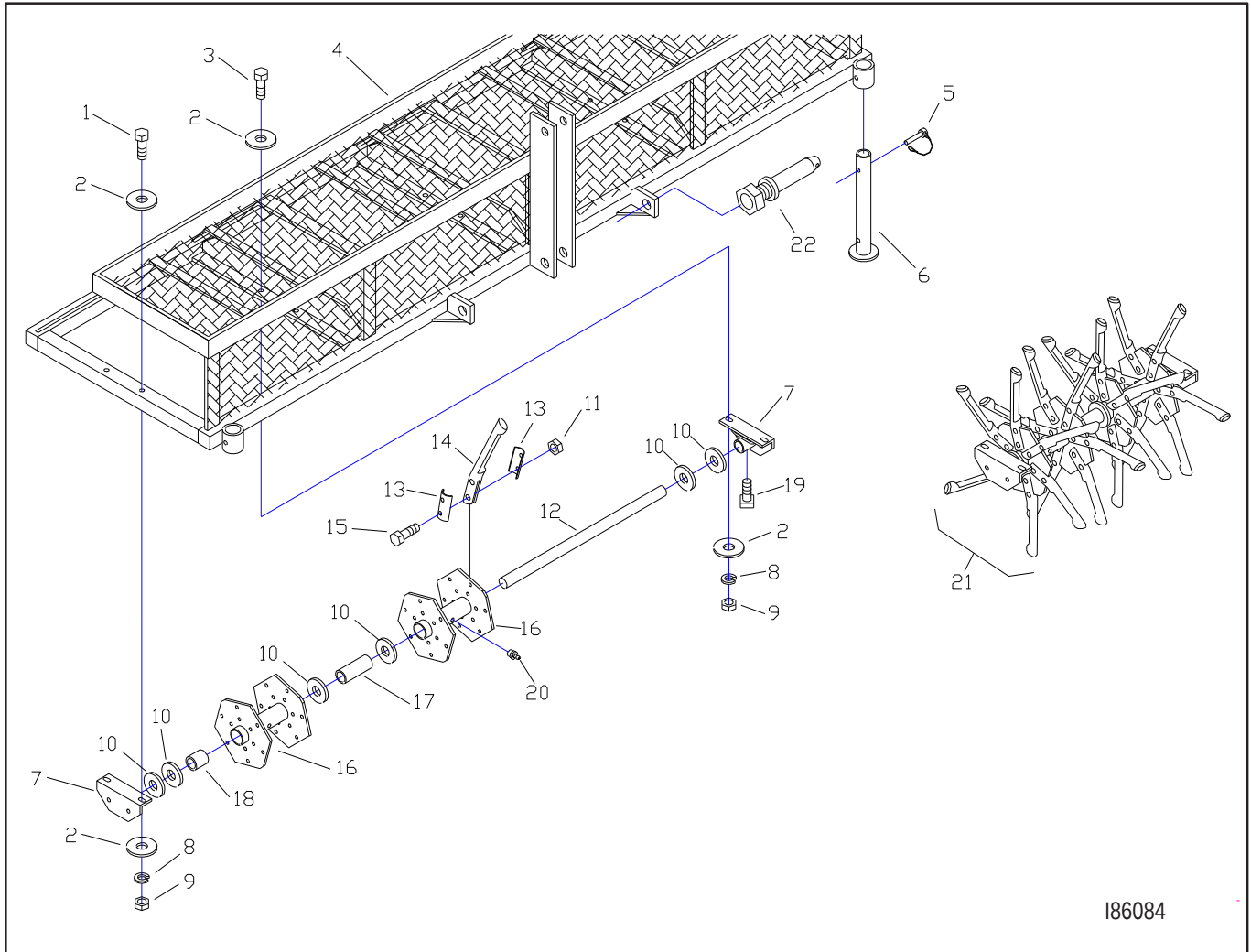

Figure A1 - Commercial Aerator Component Parts Detail

**Commercial Aerator Component Parts (continued)**

ITEM #	PART #	QTY PER MODEL			PART DESCRIPTION
		420	630	840	
1	34242	4	4	4	3/8 x 2 -1/2 Bolt
2	34018	16	24	32	3/8 Washer
3	34255	4	8	12	3/8 x 1-1/2 Bolt
4	280235	1	--	--	Model 420 Frame
	280150	--	1	--	Model 630 Frame
	280247	--	--	1	Model 840 Frame
5	220127	2	2	2	Pin
6	280132	2	2	2	Support Post
7	280156	4	6	8	Spool Bracket
8	34141	8	12	16	3/8 Lock Washer
9	34087	8	12	16	3/8 Nut
10	34193	12	18	24	1" Washer
11	34095	96	144	192	3/8 Lock Nut
12	280162	2	3	4	Shaft
13	220144	96	144	192	Spoon Holder
14	220126	48	72	96	Spoon
15	34192	96	144	192	3/8 x 1-3/4 Bolt
16	280160	4	6	8	Spool (includes items # 18, 20)
17	280152	2	3	4	Spacer Tube
18	210120	8	12	16	Bushing
19	34208	4	6	8	3/8 x 1 Set Screw
20	220101	4	6	8	Lube Fitting
21	280161	2	3	4	Section Assembly (Complete)
22	215117	2	2	2	Category 1, 3-point Pin (.875 diameter)

## Commercial Aerator: Slicing Blades Option

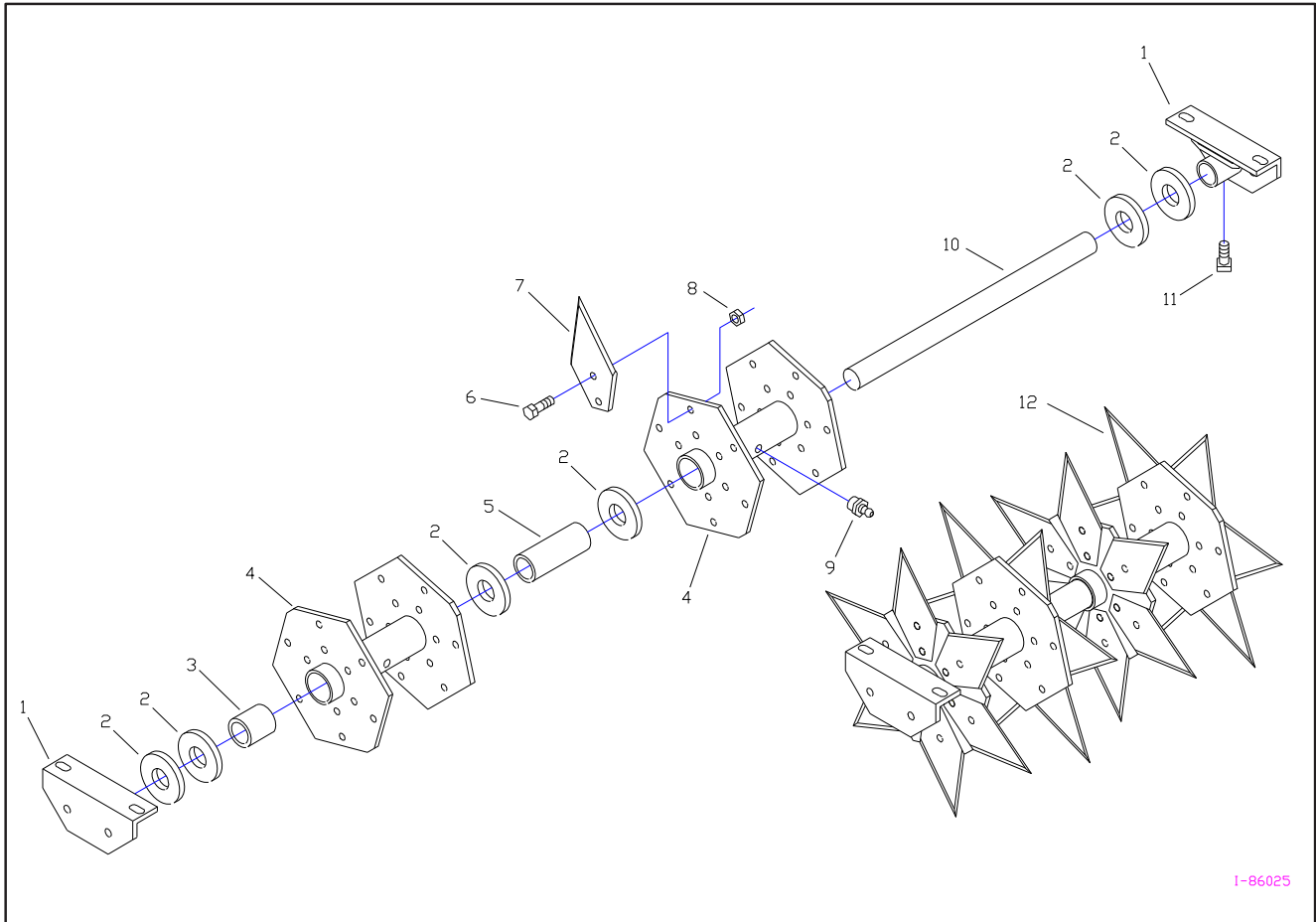

Figure A2 - Commercial Aerator Slicing Blades Parts Detail

<u>Item#</u>	<u>Millcreek Part#</u>	<u>Qty. (per section)</u>	<u>Component Description</u>
1	280156	2	Spool Bracket
2	34193	6	1" Washer
3	210120	4	Bushing
4	280160	2	Spool (includes items 3, 9)
5	280152	1	Spacer Tube
6	34190	48	3/8 x 1 Bolt
7	220135	24	Slicer Blade
8	34095	48	3/8 Lock Nut
9	220101	2	Lube Fitting
10	280162	1	Shaft
11	34208	2	3/8 x 1 Set Screw
12	280270	1	Section Assembly (Complete)



## APPENDIX B: TOW-BEHIND MODEL PARTS REFERENCE

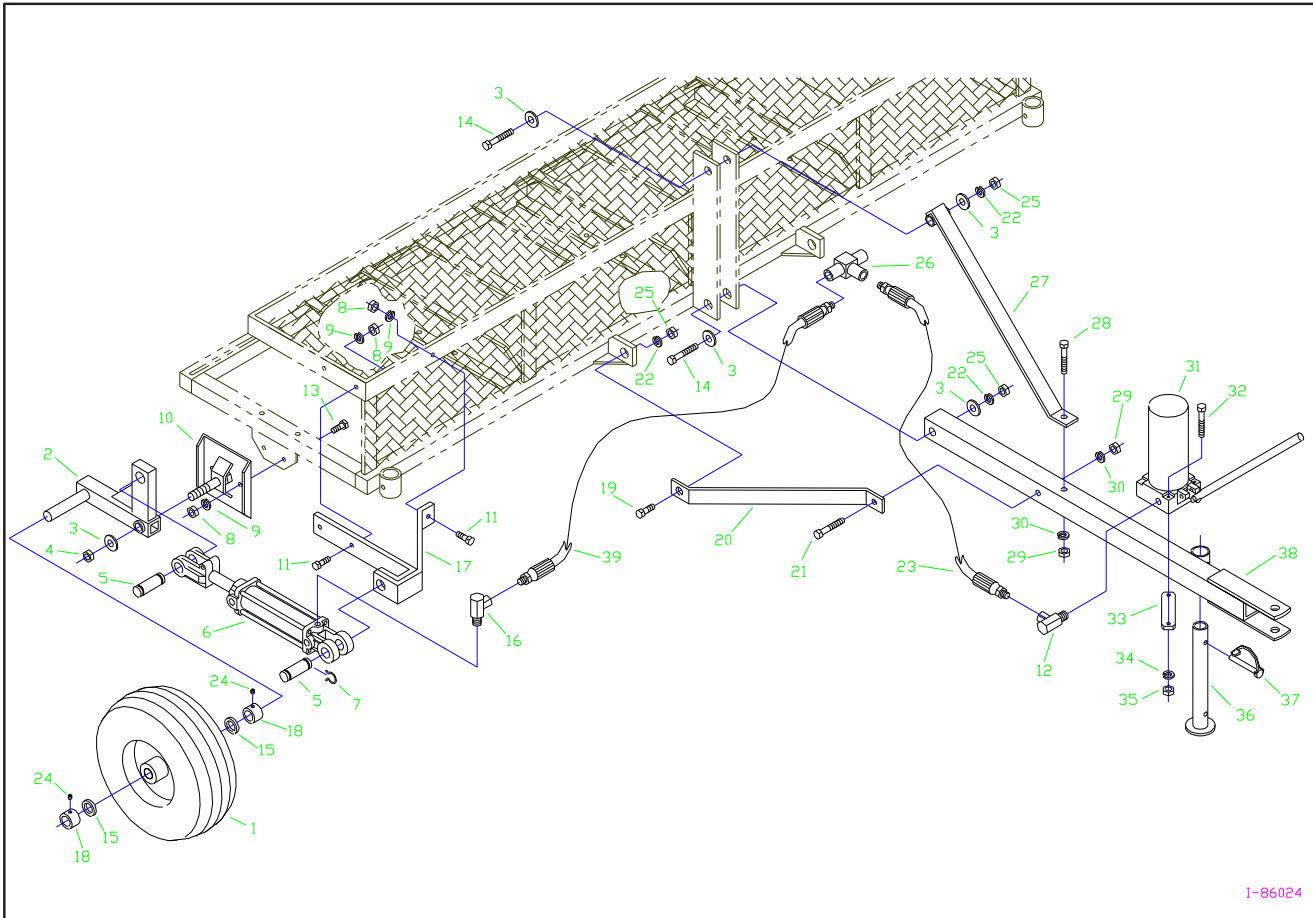

Figure B1 - Component Parts Detail for Tow-Behind Commercial Aerator Models

<b>Item#</b>	<b>Millcreek Part#</b>	<b>Qty.</b>	<b>Component Description</b>
1	215157	2	Wheel
2	280265	1	Left Wheel Arm
	280292	1	Right Wheel Arm
3	34144	6	3/4 Washer
4	34265	2	3/4 Nylon Stop Nut
5	220132	4	Pin
6	240100	2	Hydraulic Cylinder (includes item #5, 7)
7	220133	8	Clip
8	34087	10	3/8 Nut
9	34141	10	3/8 Lock Washer
10	280264	2	Wheel Bracket
11	34224	6	3/8 x 1-1/4 Bolt
12	240109	1	9/16 Elbow NPT Swivel

## Commercial Aerator Tow-Behind Models: Parts Detail (continued)

<u>Item#</u>	<u>Millcreek Part#</u>	<u>Qty.</u>	<u>Component Description</u>
13	34197	4	3/8 x 3/4 Bolt
14	34286	2	3/4 x 4 Bolt
15	34216	4	1" Washer
16	240104	2	3/8 Elbow NPT Swivel
17	280263	2	Cylinder Bracket
18	210226	4	1" Shaft Collar
19	34285	2	3/4 x 2 Bolt
20	280267	2	Hitch Side Support
21	34269	1	1/2 x 4 Bolt
22	34264	4	3/4 Lock Washer
23	240106	1	Hose 1/4 x 24"
24	N/A	4	Set Screw
25	34143	4	3/4 Nut
26	240103	1	1/4 Tee
27	280266	1	Hitch Upper Support
28	34268	1	1/2 x 3-1/2 Bolt
29	34034	2	1/2 Nut
30	34035	2	1/2 Lock Washer
31	240110	1	Hydraulic Hand Pump
32	34277	2	1/4 x 4 Bolt
33	280269	1	Pump Mount Bracket
34	34235	2	1/4 Lock Washer
35	34003	2	1/4 Nut
36	280132	1	Support Post
37	220127	1	Pin
38	280268	1	Hitch
39	240107	2	Hose 1/4 x 36" (for Model 630)

**NOTE:** The Tow-Behind Aerators are shipped completely assembled from the factory.